

Reverse-Conducting GTO Thyristors AFGR 3000-90-CV-DA



Key Parameters

I_{TQRM}	=	3000	A
$I_{T(AV)}$	=	900	A
V_{DRM}	=	4500	V

Application

- Inverters
- D.C. choppers
- Induction heaters
- D.C. to D.C. converters

MAXIMUM RATINGS

Symbols and parameters		Voltage class	Unit
V_{DRM}	Repetitive peak off-state voltage	4500	V
V_{DSM}	Non-repetitive peak off-state voltage	4500	V
$V_{D(DC)}$	DC off-state voltage	2500	V

Symbols and parameters			Value	Unit
I_{TQRM}	Repetitive controllable on-state current	$V_{DM} = 3375V,$ $T_j = 125^\circ C,$ $C_S = 3.5\mu F, L_S = 0.2\mu H$	3000	A
$I_{T(RMS)}$	RMS on-state current		1410	A
$I_{T(AV)}$	Average on-state current	$f = 60Hz,$ sine wave $\theta = 180^\circ, T_f = 70^\circ C$	900	A
I_{TSM}	Surge (non-repetitive) on-state current	One half cycle at 60Hz	18	kA
I^2t	I^2t for fusing	One cycle at 60Hz	1.3×10^6	A^2s
$I_{R(RMS)}$	RMS Reverse current		1100	A
$I_{R(AV)}$	Average reverse current	$f = 60Hz,$ sine wave $\theta = 180^\circ, T_f = 70^\circ C$	700	A
I_{RSM}	Surge (non-repetitive) reverse current	One half cycle at 60Hz	22	kA
IR^2t	Current-squared, time integration	One cycle at 60Hz	2.0×10^6	A^2s

Symbols and parameters			Value	Unit
di_T/dt	Critical rate of rise of on-state current	$V_D = 2250V, I_{GM} = 40A,$ $T_j = 125^\circ C$	500	A/ μs
V_{FGM}	Peak forward gate voltage		10	A
V_{RGM}	Peak reverse gate voltage		18	W
I_{FGM}	Peak forward gate current		100	A
I_{RGM}	Peak gate reverse current		900	W
P_{FGM}	Peak forward gate power dissipation		400	W
P_{RGM}	Peak reverse gate power dissipation		27	kW
$P_{FG(AV)}$	Average forward gate power dissipation		100	W
$P_{RG(AV)}$	Average reverse gate power dissipation		230	W

ELECTRICAL CHARACTERISTICS

Symbols and parameters			Value			Unit
			min	typ	max	
V_{TM}	On-state voltage	$T_j = 125^\circ C, I_{TM} = 3000A,$ Instantaneous measurement			4.0	V
V_{RM}	Peak reverse voltage drop	$T_j = 125^\circ C, I_{RM} = 3000A,$ Instantaneous measurement			4.0	V
I_{DRM}	Repetitive peak off-state current	$T_j = 125^\circ C, V_{DRM}$ Applied, $V_{GK} = -2V$			200	mA
I_{RG}	Reverse gate current	$T_j = 125^\circ C, V_{RG} = 17V$			250	mA
dv/dt	Critical rate of rise of off-state voltage	$T_j = 125^\circ C, V_D = 2250V,$ $V_{GK} = -2V$	1000			V/ μs
t_{gt}	Turn-on time	$T_j = 125^\circ C, I_{TM} = 3000A,$ $I_{GM} = 40A, V_D = 2250V$			10	μs
t_{gq}	Turn-off time	$T_j = 125^\circ C, I_{TM} = 3000A,$ $V_{DM} = 3375V, L_S = 0.2\mu H$			30	μs
I_{GQM}	Peak gate turn-off current	$di_{GQ}/dt = -40A/\mu s$ $V_{RG} = 17V, C_S = 3.5\mu F$		750		A
V_{GT}	Gate trigger voltage	DC METHOD: $V_D = 24V,$ $R_L = 0.1\Omega, T_j = 25^\circ C$			1.5	V
I_{GT}	Gate trigger current				3000	mA

THERMAL

Symbols and parameters			Value	Unit
T_j	Junction operating temperature		-40 ... 125	°C
T_{stg}	Storage temperature range		-40 ... 150	°C
$R_{th(j-f)}$	Thermal resistance, max	GTO Side (Junction to fin)	0.016	°C/W
		Diode Side (Junction to fin)	0.025	°C/W

MECHANICAL

Symbols and parameters			Value	Unit
M	Mounting force required	Recommended value 37	31 ... 43	kN
w	Weight		1450	g

DIMENSIONES

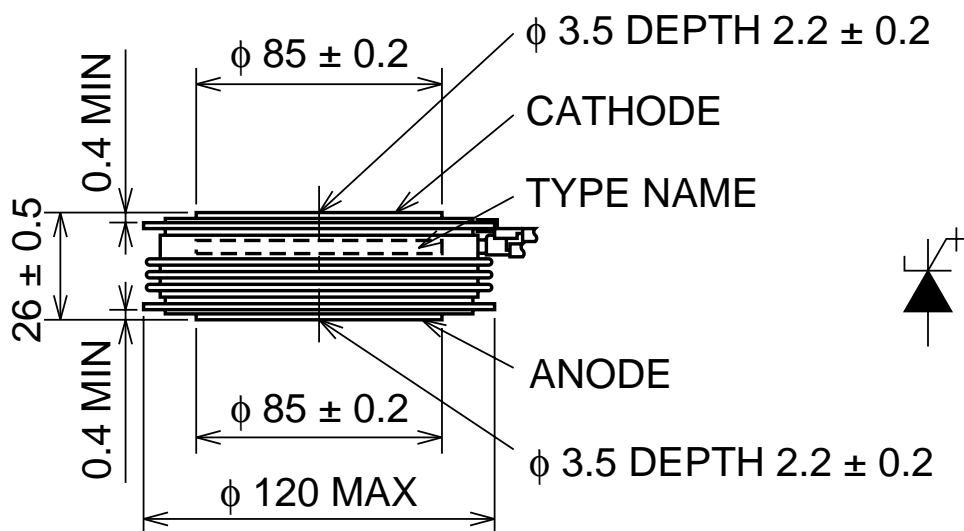
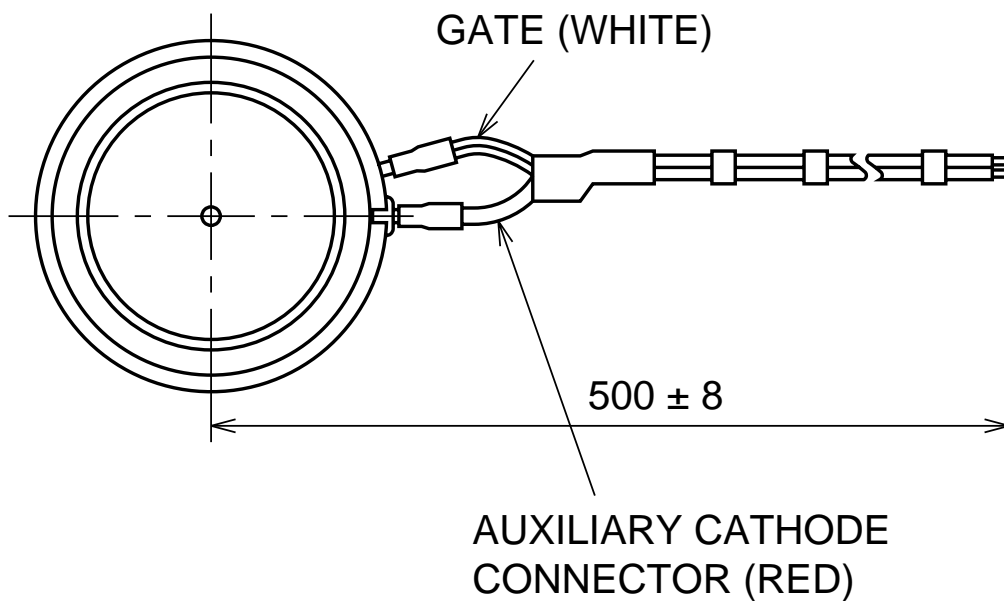

All dimensions in millimeters

MAXIMUM ON-STATE POWER DISSIPATION CHARACTERISTICS (GTO PART, SINGLE-PHASE HALF WAVE)

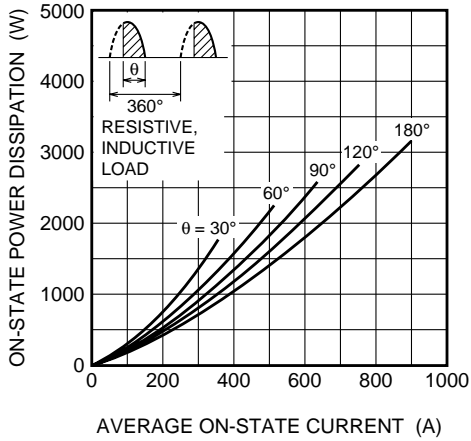

ALLOWABLE FIN TEMPERATURE VS. AVERAGE ON-STATE CURRENT (GTO PART, SINGLE-PHASE HALF WAVE)

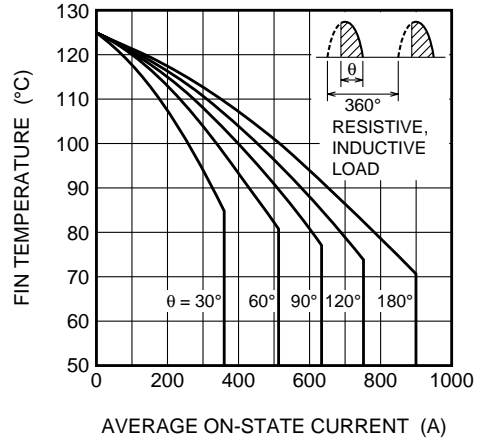

MAXIMUM ON-STATE POWER DISSIPATION CHARACTERISTICS (GTO PART, RECTANGULAR WAVE)

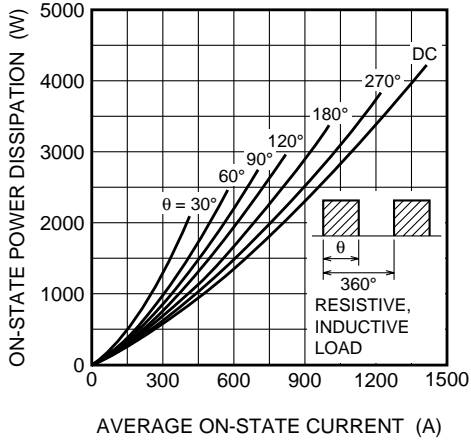

ALLOWABLE FIN TEMPERATURE VS. AVERAGE ON-STATE CURRENT (GTO PART, RECTANGULAR WAVE)

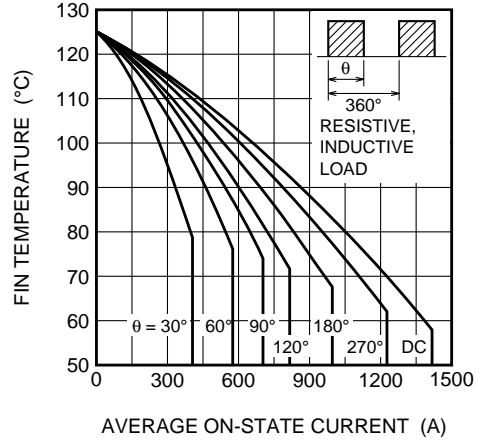

MAXIMUM REVERSE POWER DISSIPATION CHARACTERISTIC (DIODE PART, SINGLE PHASE WAVE)

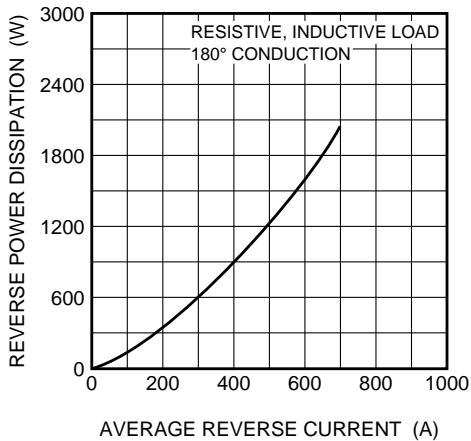

ALLOWABLE FIN TEMPERATURE VS. AVERAGE REVERSE CURRENT (DIODE PART, SINGLE PHASE HALF WAVE)

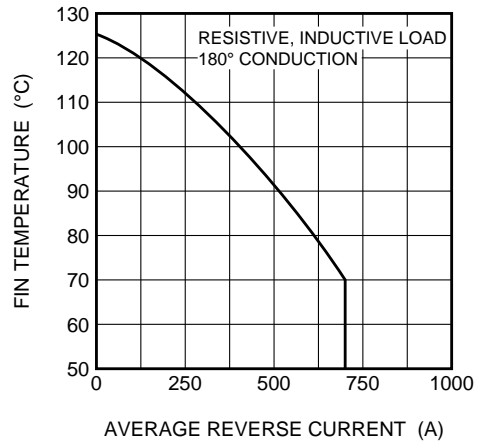

GATE TRIGGER CURRENT VS. JUNCTION TEMPERATURE (TYPICAL)

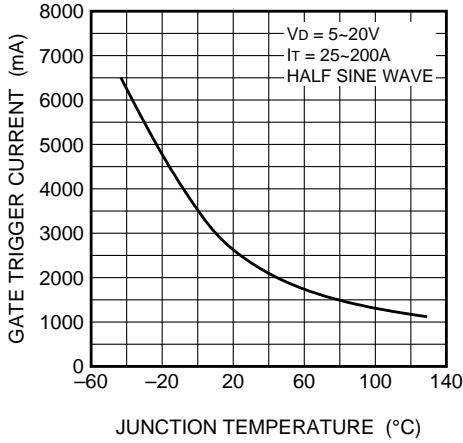

TURN ON TIME, TURN ON DELAY TIME VS. TURN ON GATE CURRENT (TYPICAL)

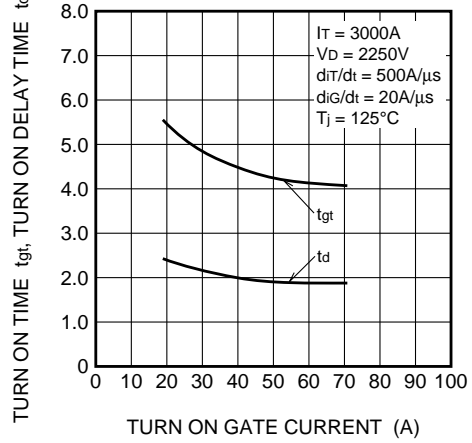

TURN OFF TIME, TURN OFF STORAGE TIME VS. TURN OFF GATE CURRENT (TYPICAL)

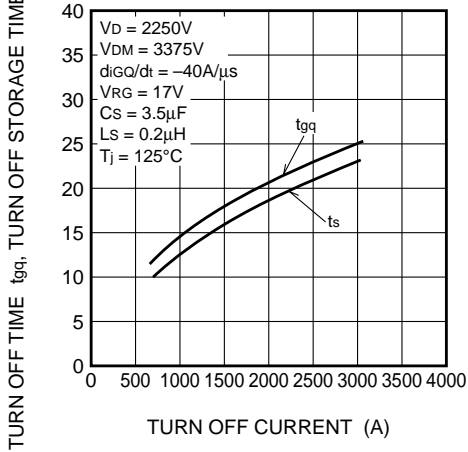

TURN OFF TIME, TURN OFF STORAGE TIME VS. RATE OF RISE OF TURN OFF GATE CURRENT (TYPICAL)

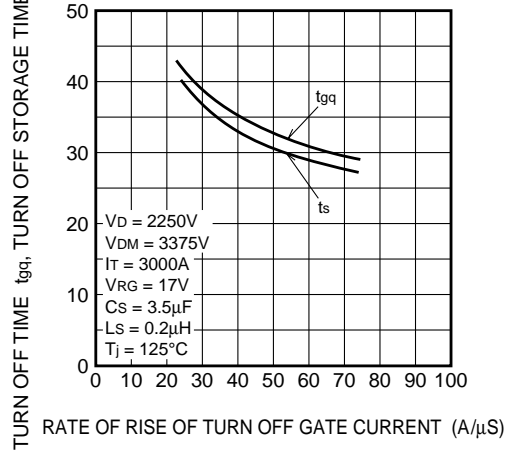

TURN OFF GATE CURRENT VS. TURN OFF CURRENT (TYPICAL)

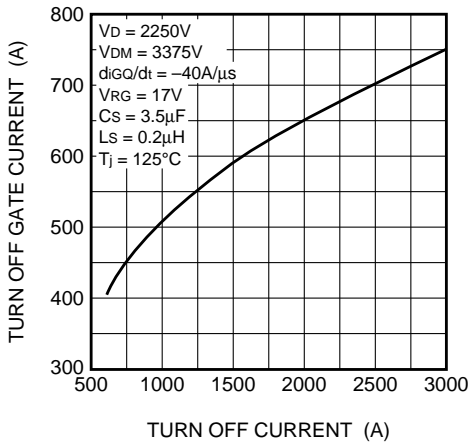

TURN OFF GATE CURRENT VS. RATE OF RISE OF GATE CURRENT (TYPICAL)

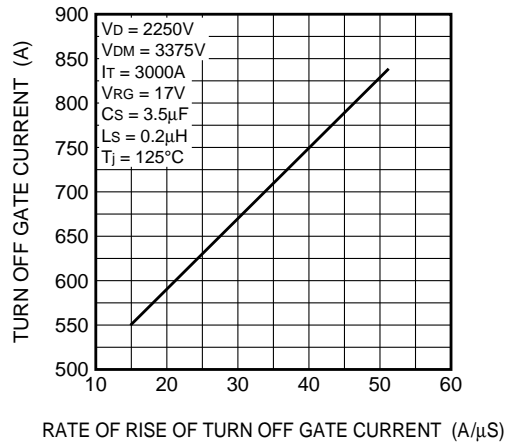

TURN ON SWITCHING ENERGY (MAXIMUM)

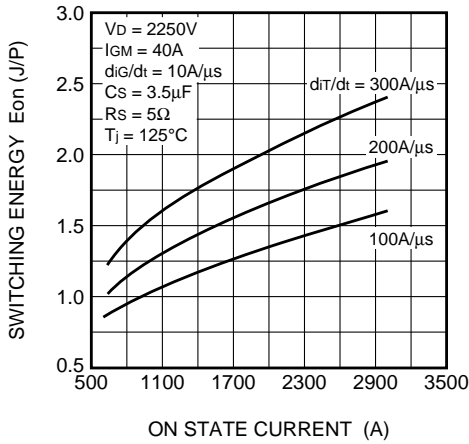

TURN OFF SWITCHING ENERGY (MAXIMUM)

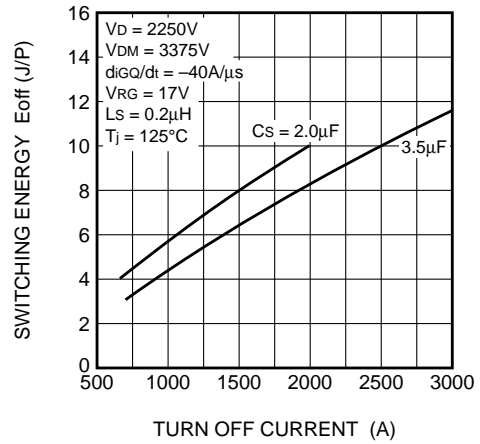

OFF STATE RECOVERY CHARGE, OFF STATE RECOVERY TIME VS. JUNCTION TEMPERATURE

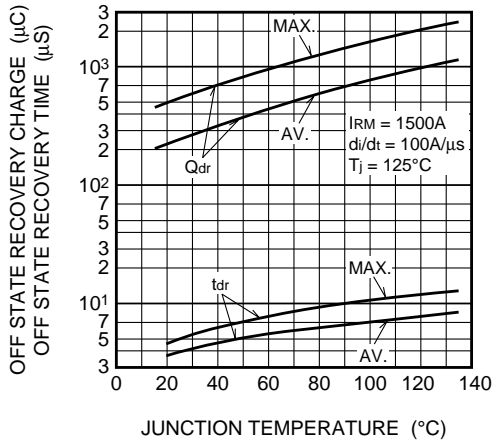

OFF STATE RECOVERY CHARGE, OFF STATE RECOVERY TIME VS. REVERSE CURRENT

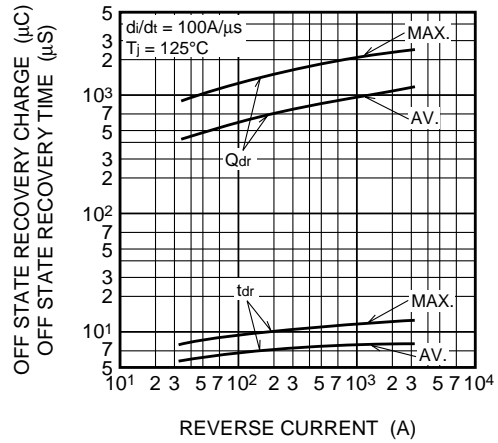

OFF STATE RECOVERY CHARGE, OFF STATE RECOVERY TIME VS. RATE OF DECREASE OF REVERSE CURRENT

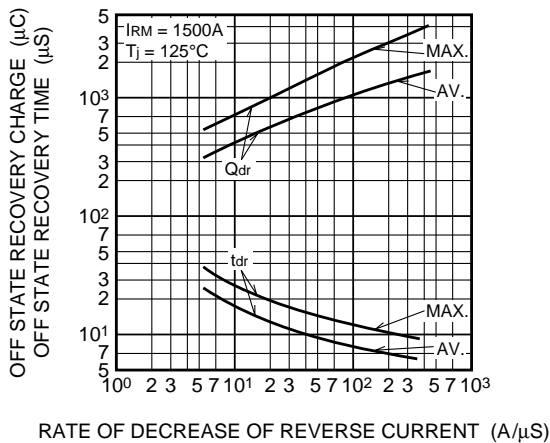

OFF STATE RECOVERY LOSS(DIODE PART) VS. REVERSE CURRENT (TYPICAL)

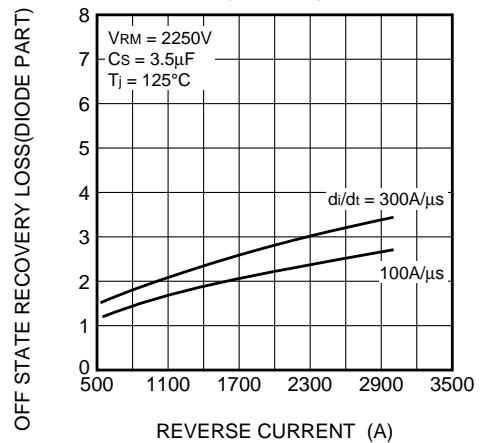

MAXIMUM ON-STATE AND MAXIMUM REVERSE CHARACTERISTICS

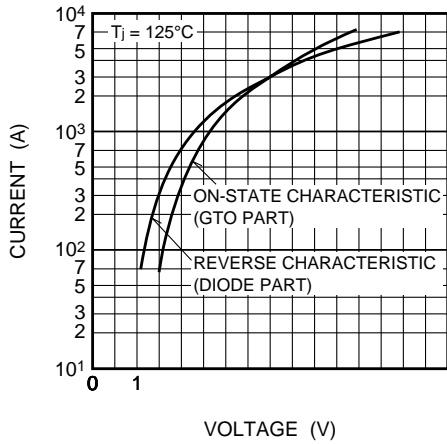

RATED ON-STATE AND REVERSE SURGE CURRENT

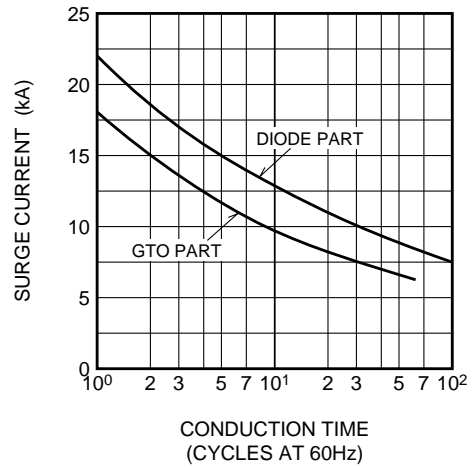

GATE CHARACTERISTICS

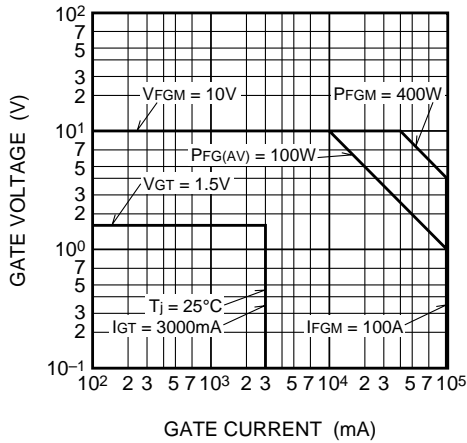

MAXIMUM THERMAL IMPEDANCE CHARACTERISTICS (JUNCTION TO FIN)

