



### Key Parameters

$I_{TQRM}$	=	4000 A
$I_{T(AV)}$	=	1200 A
$V_{DRM}$	=	4500 V

### Application

- Inverters
- D.C. choppers
- Induction heaters
- D.C. to D.C. converters

### MAXIMUM RATINGS

Symbols and parameters		Voltage class	Unit
$V_{RRM}$	Repetitive peak reverse voltage	19	V
$V_{RSM}$	Non-repetitive peak reverse voltage	19	V
$V_{R(DC)}$	DC reverse voltage	19	V
$V_{DRM}$	Repetitive peak off-state voltage	4500	V
$V_{DSM}$	Non-repetitive peak off-state voltage	4500	V
$V_{D(DC)}$	DC off-state voltage	2500	V

Symbols and parameters			Value	Unit
$I_{TQRM}$	Repetitive controllable on-state current	$V_{DM} = 3375V,$ $T_j = 125^\circ C,$ $C_S = 5.0\mu F, L_S = 0.2\mu H$	4000	A
$I_{T(RMS)}$	RMS on-state current		1880	A
$I_{T(AV)}$	Average on-state current	$f = 60Hz,$ sine wave $\theta = 180^\circ, T_f = 78^\circ C$	1200	A
$I_{TSM}$	Surge (non-repetitive) on-state current	One half cycle at 60Hz	20	kA
$I^2t$	Current-squared, time integration	One cycle at 60Hz	$1.7 \times 10^6$	$A^2s$
$di_T/dt$	Critical rate of rise of on-state current	$V_D = 3400V, I_{GM} = 40A,$ $T_j = 125^\circ C$	500	$A/\mu s$
$V_{FGM}$	Peak forward gate voltage		10	V
$V_{RGM}$	Peak reverse gate voltage		19	V

Symbols and parameters			Value	Unit
$I_{FGM}$	Peak forward gate current		130	A
$I_{RGM}$	Max. RMS on-state current		1100	A
$P_{FGM}$	Peak forward gate power dissipation		520	W
$P_{RGM}$	Peak reverse gate power dissipation		33	kW
$P_{FG(AV)}$	Max. peak non-repetitive surge current		130	W
$P_{RG(AV)}$	Limiting load integral		300	W

### ELECTRICAL CHARACTERISTICS

Symbols and parameters			Value			Unit
			min	typ	max	
$V_{TM}$	On-state voltage	$T_j = 125^\circ\text{C}$ , $I_{TM} = 4000\text{A}$ , Instantaneous measurement			4.0	V
$I_{RRM}$	Repetitive peak reverse current	$T_j = 125^\circ\text{C}$ , $V_{RRM}$ Applied			100	mA
$I_{DRM}$	Repetitive peak off-state current	$T_j = 125^\circ\text{C}$ , $V_{DRM}$ Applied, $V_{GK} = -2\text{V}$			150	mA
$I_{RG}$	Reverse gate current	$T_j = 125^\circ\text{C}$ , $V_{RG} = 19\text{V}$			100	mA
$dv/dt$	Critical rate of rise of off-state voltage	$T_j = 125^\circ\text{C}$ , $V_D = 2250\text{V}$ , $V_{GK} = -2\text{V}$	1000			V/ $\mu\text{s}$
$t_{gt}$	Turn-on time	$T_j = 125^\circ\text{C}$ , $I_{TM} = 4000\text{A}$ , $I_{GM} = 40\text{A}$ , $V_D = 3400\text{V}$			10	$\mu\text{s}$
$t_{gq}$	Turn-off time	$T_j = 125^\circ\text{C}$ , $I_{TM} = 4000\text{A}$ , $V_{DM} = 3375\text{V}$ , $di_{GQ}/dt = -50\text{A}/\mu\text{s}$			40	$\mu\text{s}$
$I_{GQM}$	Peak gate turn-off current	$V_{RG} = 17\text{V}$ , $C_S = 5.0\mu\text{F}$ , $L_S = 0.2\mu\text{H}$		1000		A
$V_{GT}$	Gate trigger voltage	DC METHOD: $V_D = 24\text{V}$ , $R_L = 0.1\Omega$ , $T_j = 25^\circ\text{C}$			1.5	V
$I_{GT}$	Gate trigger current				4000	mA

**THERMAL**

Symbols and parameters			Value	Unit
$T_j$	Junction operating temperature		-40 ... 125	°C
$T_{stg}$	Storage temperature range		-40 ... 150	°C
$R_{th(j-f)}$	Thermal resistance, max	Junction to fin	0.010	°C/W

**MECHANICAL**

Symbols and parameters			Value	Unit
$M$	Mounting force required	Recommended value 47	38 ... 54	kN
$w$	Weight		1600	g

DIMENSIONES

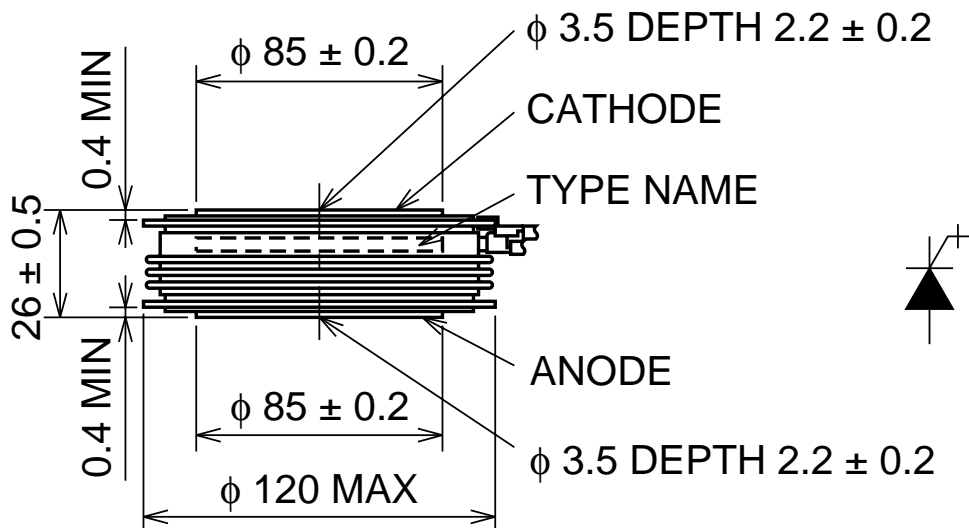
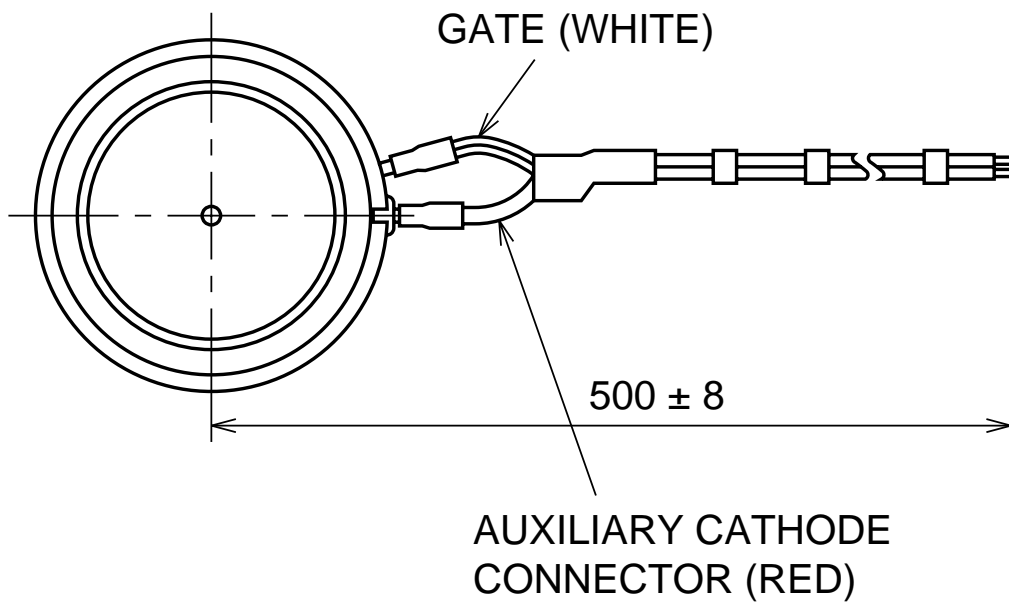

All dimensions in millimeters

**MAXIMUM ON-STATE POWER DISSIPATION CHARACTERISTICS (SINGLE-PHASE HALF WAVE)**

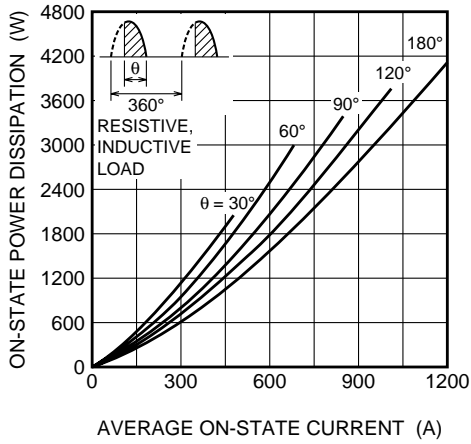

**ALLOWABLE FIN TEMPERATURE VS. AVERAGE ON-STATE CURRENT (SINGLE-PHASE HALF WAVE)**

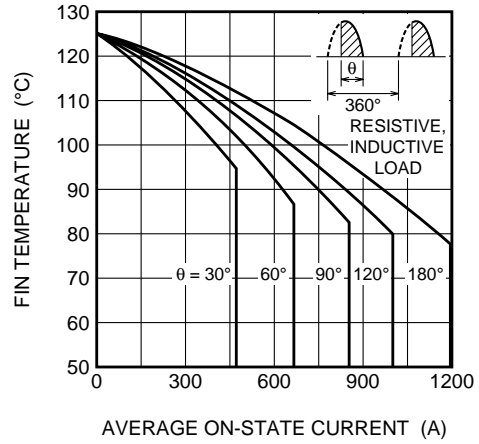

**MAXIMUM ON-STATE POWER DISSIPATION CHARACTERISTICS (RECTANGULAR WAVE)**

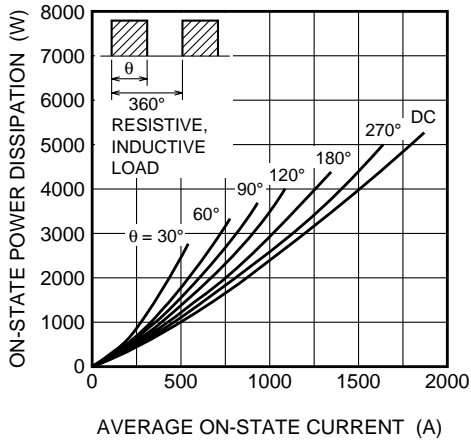

**ALLOWABLE FIN TEMPERATURE VS. AVERAGE ON-STATE CURRENT (RECTANGULAR WAVE)**

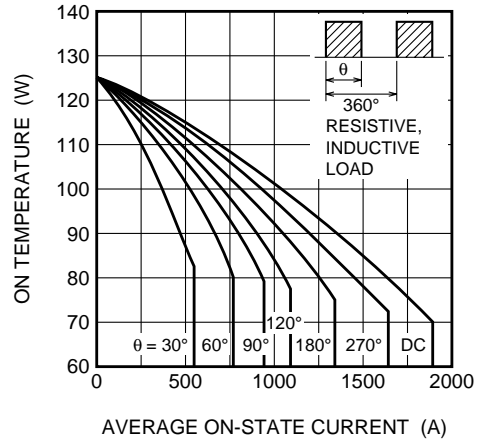

**GATE TRIGGER CURRENT VS. JUNCTION TEMPERATURE (TYPICAL)**

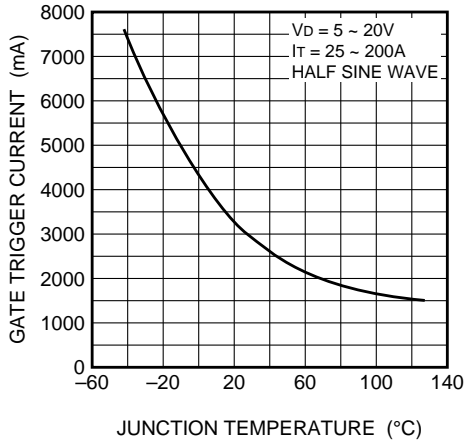

**TURN ON TIME, TURN ON DELAY TIME VS. TURN ON GATE CURRENT (TYPICAL)**

