



Key Parameters

I_{TQRM}	=	3300 A
$I_{T(AV)}$	=	1000 A
V_{DRM}	=	2500 V

Application

- Inverters
- D.C. choppers
- Induction heaters
- D.C. to D.C. converters

MAXIMUM RATINGS

Symbols and parameters		Voltage class	Unit
V_{RRM}	Repetitive peak reverse voltage	17	V
V_{RSM}	Non-repetitive peak reverse voltage	17	V
$V_{R(DC)}$	DC reverse voltage	17	V
V_{DRM}	Repetitive peak off-state voltage	2500	V
V_{DSM}	Non-repetitive peak off-state voltage	2500	V
$V_{D(DC)}$	DC off-state voltage	2000	V

Symbols and parameters			Value	Unit
I_{TQRM}	Repetitive controllable on-state current	$V_{DM} = 1875V,$ $T_j = 125^{\circ}C,$ $C_S = 6.0\mu F, L_S = 0.2\mu H$	3300	A
$I_{T(RMS)}$	RMS on-state current		1570	A
$I_{T(AV)}$	Average on-state current	$f = 60Hz,$ sine wave $\theta = 180^{\circ}, T_f = 81^{\circ}C$	1000	A
I_{TSM}	Surge (non-repetitive) on-state current	One half cycle at 60Hz	24	kA
I^2t	Current-squared, time integration	One cycle at 60Hz	2.4×10^6	A^2s
di_T/dt	Critical rate of rise of on-state current	$V_D = 1250V, I_{GM} = 40A,$ $T_j = 125^{\circ}C$	500	$A/\mu s$
V_{FGM}	Peak forward gate voltage		10	V
V_{RGM}	Peak reverse gate voltage		17	V

Symbols and parameters			Value	Unit
I_{FGM}	Peak forward gate current		100	A
I_{RGM}	Max. RMS on-state current		1100	A
P_{FGM}	Peak forward gate power dissipation		400	W
P_{RGM}	Peak reverse gate power dissipation		27	kW
$P_{FG(AV)}$	Max. peak non-repetitive surge current		100	W
$P_{RG(AV)}$	Limiting load integral		230	W

ELECTRICAL CHARACTERISTICS

Symbols and parameters			Value			Unit
			min	typ	max	
V_{TM}	On-state voltage	$T_j = 125^\circ\text{C}$, $I_{TM} = 3300\text{A}$, Instantaneous measurement			3.0	V
I_{RRM}	Repetitive peak reverse current	$T_j = 125^\circ\text{C}$, V_{RRM} Applied			300	mA
I_{DRM}	Repetitive peak off-state current	$T_j = 125^\circ\text{C}$, V_{DRM} Applied, $V_{GK} = -2\text{V}$			150	mA
I_{RG}	Reverse gate current	$T_j = 125^\circ\text{C}$, $V_{RG} = 17\text{V}$			300	mA
dv/dt	Critical rate of rise of off-state voltage	$T_j = 125^\circ\text{C}$, $V_D = 1250\text{V}$, $V_{GK} = -2\text{V}$	1000			V/ μs
t_{gt}	Turn-on time	$T_j = 125^\circ\text{C}$, $I_{TM} = 3300\text{A}$, $I_{GM} = 40\text{A}$, $V_D = 1250\text{V}$			10	μs
t_{gq}	Turn-off time	$T_j = 125^\circ\text{C}$, $I_{TM} = 3300\text{A}$, $V_{DM} = 1875\text{V}$, $di_{GQ}/dt = -40\text{A}/\mu\text{s}$			35	μs
I_{GQM}	Peak gate turn-off current	$V_{RG} = 17\text{V}$, $C_S = 6.0\mu\text{F}$, $L_S = 0.2\mu\text{H}$		780		A
V_{GT}	Gate trigger voltage	DC METHOD: $V_D = 24\text{V}$, $R_L = 0.1\Omega$, $T_j = 25^\circ\text{C}$			1.5	V
I_{GT}	Gate trigger current				4000	mA

THERMAL

Symbols and parameters			Value	Unit
T_j	Junction operating temperature		-40 ... 125	°C
T_{stg}	Storage temperature range		-40 ... 150	°C
$R_{th(j-f)}$	Thermal resistance, max	Junction to fin	0.015	°C/W

MECHANICAL

Symbols and parameters			Value	Unit
M	Mounting force required	Recommended value 33	30 ... 40	kN
w	Weight		1220	g

DIMENSIONES

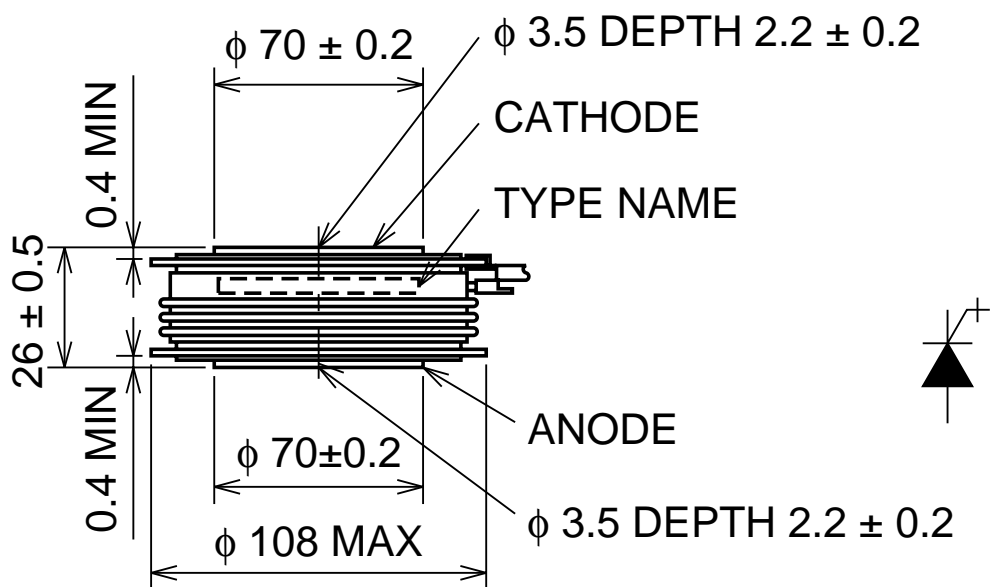
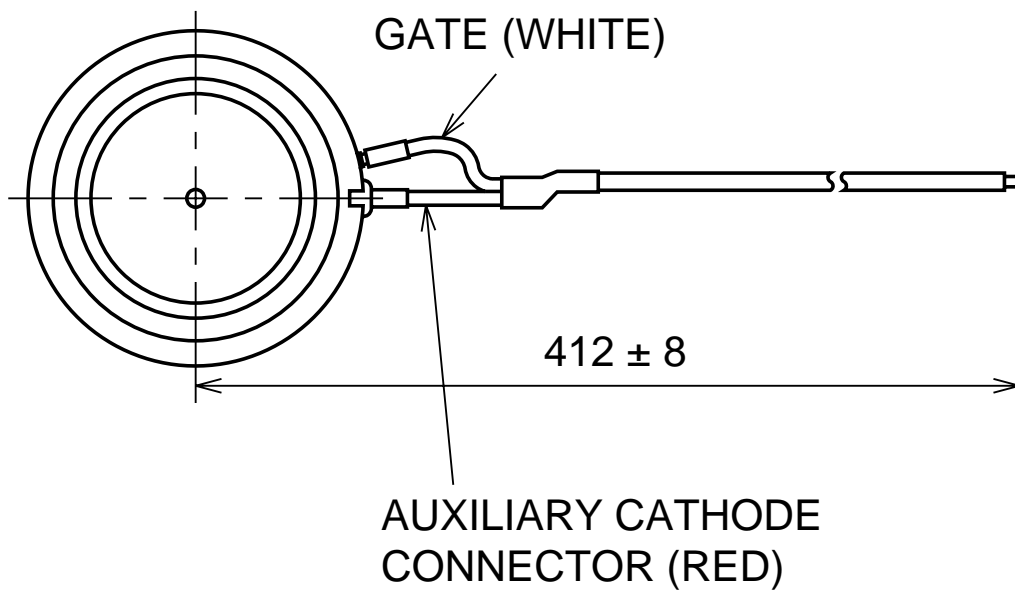

All dimensions in millimeters

MAXIMUM ON-STATE POWER DISSIPATION CHARACTERISTICS (SINGLE-PHASE HALF WAVE)

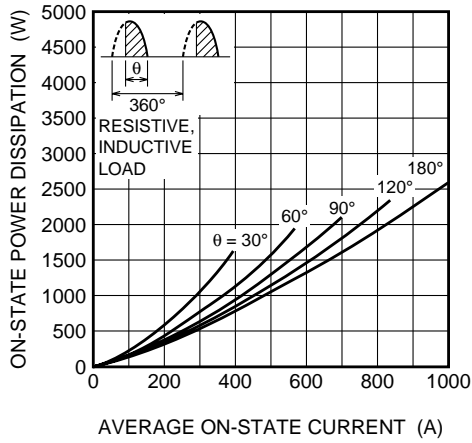

ALLOWABLE FIN TEMPERATURE VS. AVERAGE ON-STATE CURRENT (SINGLE-PHASE HALF WAVE)

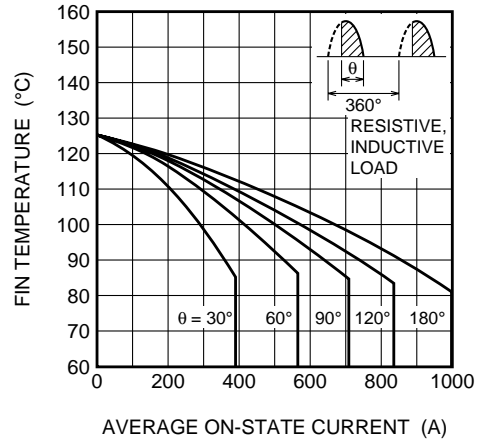

MAXIMUM ON-STATE POWER DISSIPATION CHARACTERISTICS (RECTANGULAR WAVE)

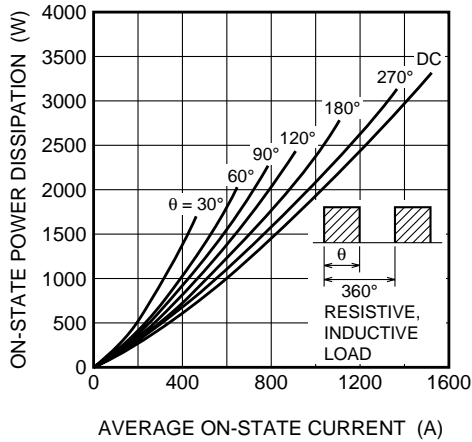

ALLOWABLE FIN TEMPERATURE VS. AVERAGE ON-STATE CURRENT (RECTANGULAR WAVE)

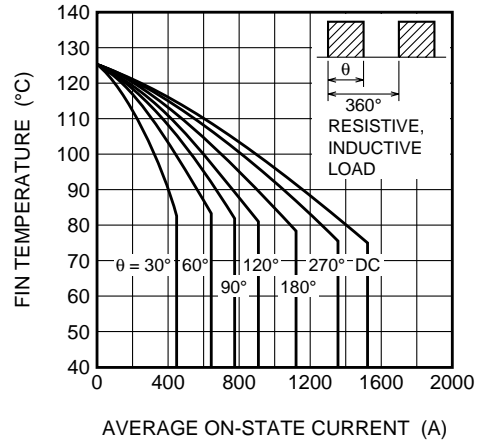

GATE TRIGGER CURRENT VS. JUNCTION TEMPERATURE (TYPICAL)

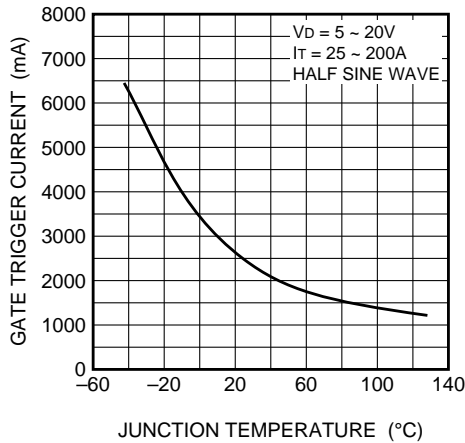

TURN ON TIME, TURN ON DELAY TIME VS. TURN ON GATE CURRENT (TYPICAL)

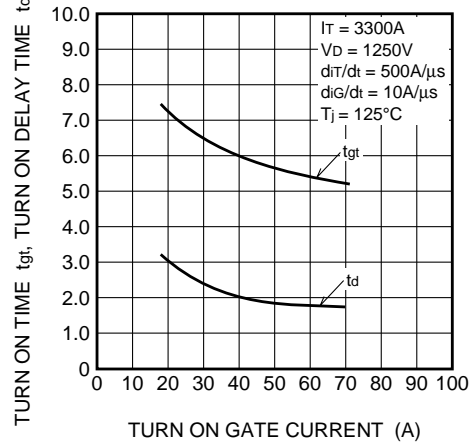

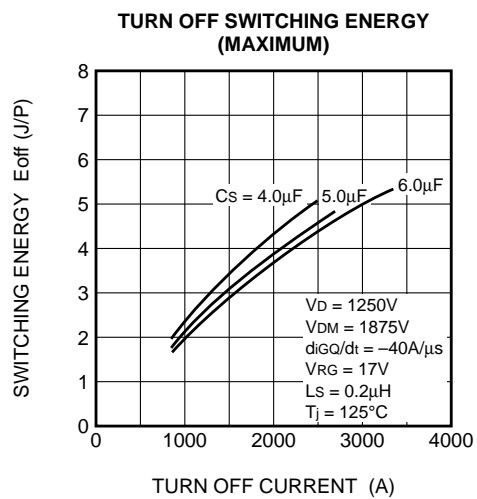
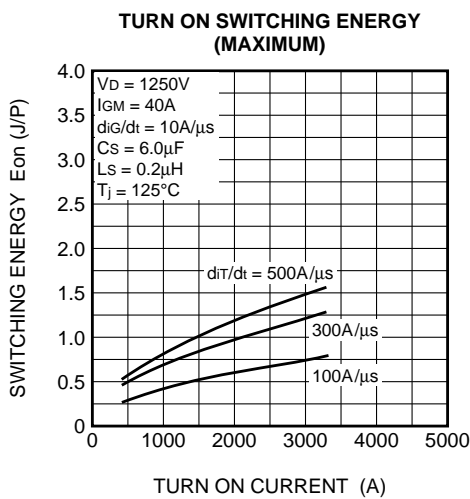
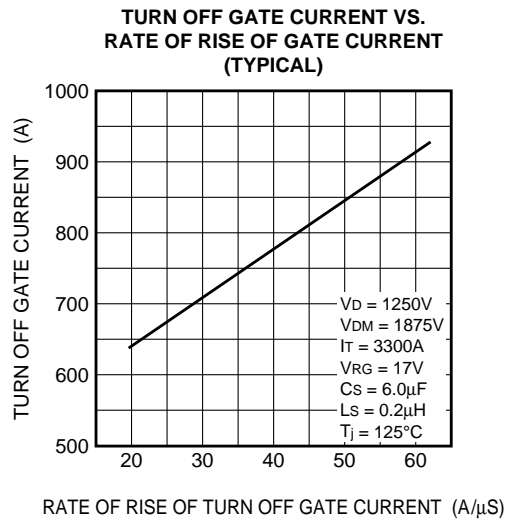
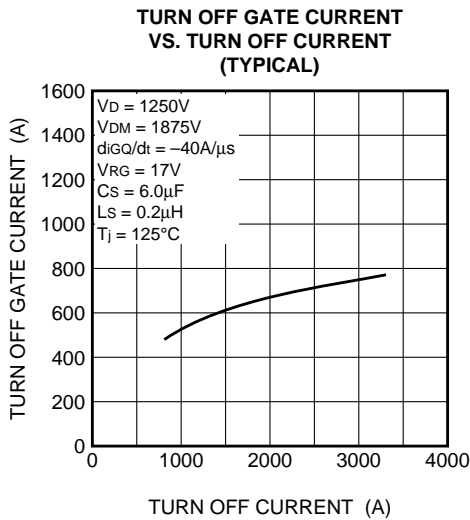
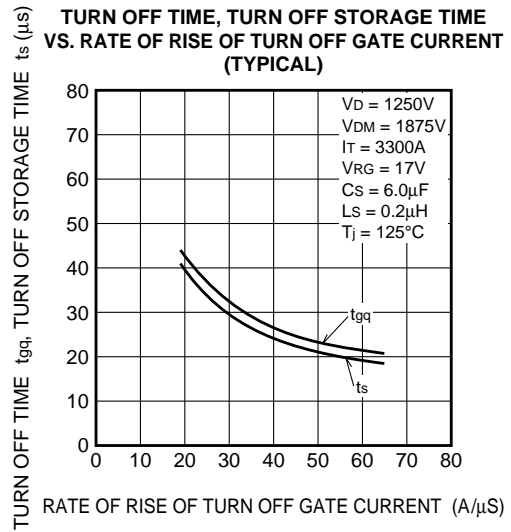
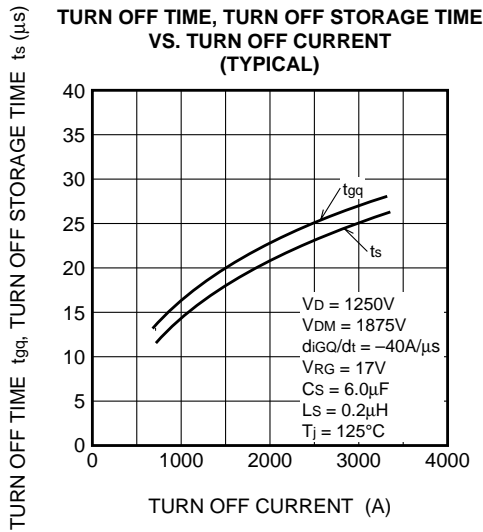

MAXIMUM ON-STATE CHARACTERISTIC

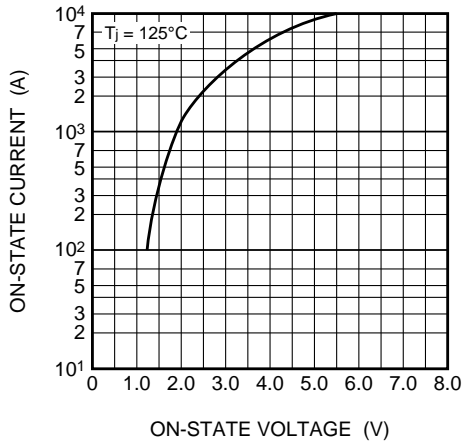

RATED SURGE ON-STATE CURRENT

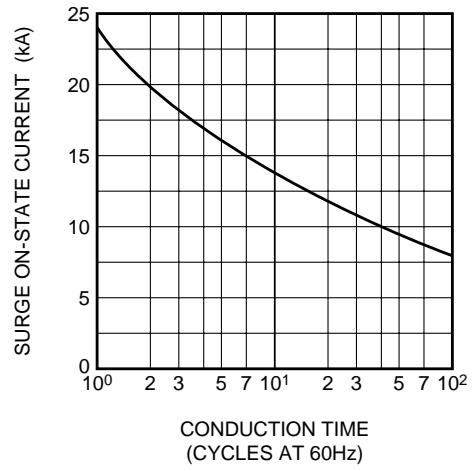

GATE CHARACTERISTICS

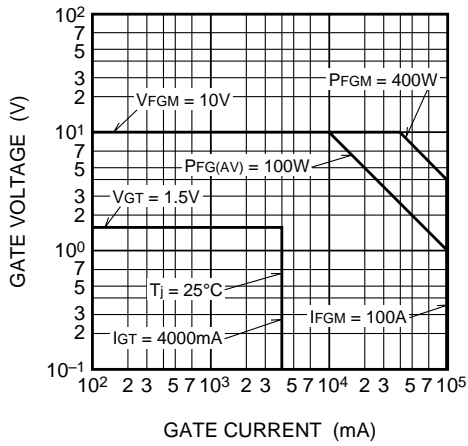

MAXIMUM THERMAL IMPEDANCE CHARACTERISTIC (JUNCTION TO FIN)

