



Key Parameters

I_{TQRM}	=	2000 A
$I_{T(AV)}$	=	600 A
V_{DRM}	=	4500 V

Application

- Inverters
- D.C. choppers
- Induction heaters
- D.C. to D.C. converters

MAXIMUM RATINGS

Symbols and parameters		Voltage class	Unit
V_{RRM}	Repetitive peak reverse voltage	17	V
V_{RSM}	Non-repetitive peak reverse voltage	17	V
$V_{R(DC)}$	DC reverse voltage	17	V
V_{DRM}	Repetitive peak off-state voltage	4500	V
V_{DSM}	Non-repetitive peak off-state voltage	4500	V
$V_{D(DC)}$	DC off-state voltage	3600	V

Symbols and parameters			Value	Unit
I_{TQRM}	Repetitive controllable on-state current	$V_D = 2250V,$ $V_{DM} = 3375V, T_j = 125^\circ C,$ $C_S = 4.0\mu F, L_S = 0.3\mu H$	2000	A
$I_{T(RMS)}$	RMS on-state current		940	A
$I_{T(AV)}$	Average on-state current	$f = 60Hz,$ sine wave $\theta = 180^\circ, T_f = 70^\circ C$	600	A
I_{TSM}	Surge (non-repetitive) on-state current	One half cycle at 60Hz	13	kA
I^2t	Current-squared, time integration	One cycle at 60Hz	7×10^5	A ² s
di_T/dt	Critical rate of rise of on-state current	$V_D = 2250V, I_{GM} = 30A,$ $T_j = 125^\circ C$	500	A/ μs
V_{FGM}	Peak forward gate voltage		10	V
V_{RGM}	Peak reverse gate voltage		17	V

Symbols and parameters			Value	Unit
I_{FGM}	Peak forward gate current		50	A
I_{RGM}	Max. RMS on-state current		700	A
P_{FGM}	Peak forward gate power dissipation		250	W
P_{RGM}	Peak reverse gate power dissipation		23.8	kW
$P_{FG(AV)}$	Max. peak non-repetitive surge current		50	W
$P_{RG(AV)}$	Limiting load integral		150	W

ELECTRICAL CHARACTERISTICS

Symbols and parameters			Value			Unit
			min	typ	max	
V_{TM}	On-state voltage	$T_j = 125^\circ\text{C}$, $I_{TM} = 2000\text{A}$, Instantaneous measurement			3.5	V
I_{RRM}	Repetitive peak reverse current	$T_j = 125^\circ\text{C}$, V_{RRM} Applied			100	mA
I_{DRM}	Repetitive peak off-state current	$T_j = 125^\circ\text{C}$, V_{DRM} Applied, $V_{GK} = -2\text{V}$			100	mA
I_{RG}	Reverse gate current	$T_j = 125^\circ\text{C}$, $V_{RG} = 17\text{V}$			100	mA
dv/dt	Critical rate of rise of off-state voltage	$T_j = 125^\circ\text{C}$, $V_D = 2250\text{V}$, $V_{GK} = -2\text{V}$	1000			V/ μs
t_{gt}	Turn-on time	$T_j = 125^\circ\text{C}$, $I_{TM} = 2000\text{A}$, $I_{GM} = 30\text{A}$, $V_D = 2250\text{V}$			10	μs
t_{gq}	Turn-off time	$T_j = 125^\circ\text{C}$, $I_{TM} = 2000\text{A}$, $V_D = 2250\text{V}$, $V_{DM} = 3375\text{V}$, $di_{GQ}/dt = -30\text{A}/\mu\text{s}$, $V_{RG} = 17\text{V}$, $C_S = 4.0\mu\text{F}$, $LS = 0.3\mu\text{H}$			30	μs
I_{GQM}	Peak gate turn-off current			570		A
V_{GT}	Gate trigger voltage	DC METHOD: $V_D = 24\text{V}$, $R_L = 0.1\Omega$, $T_j = 25^\circ\text{C}$			1.5	V
I_{GT}	Gate trigger current				2.5	A

THERMAL

Symbols and parameters			Value	Unit
T_j	Junction operating temperature		-40 ... 125	°C
T_{stg}	Storage temperature range		-40 ... 150	°C
$R_{th(j-f)}$	Thermal resistance, max	Junction to fin	0.017	°C/W

MECHANICAL

Symbols and parameters			Value	Unit
M	Mounting force required	Recommended value 20	18 ... 24	kN
w	Weight		760	g

DIMENSIONES

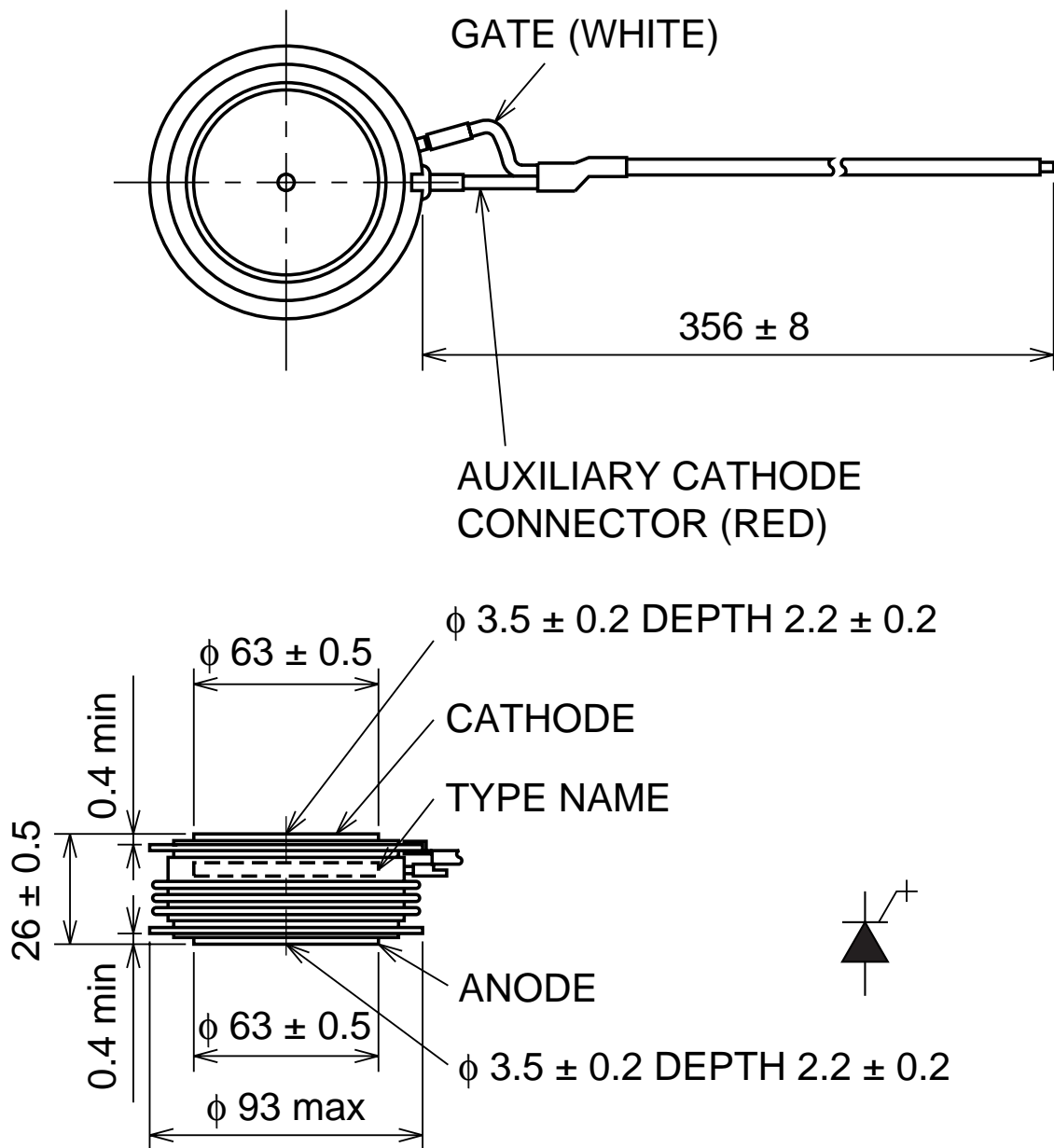

All dimensions in millimeters

