

Thyristor

AGA 4000-45-L-01



Key Parameters

V_{DRM}	=	4500 V
I_{TGQM}	=	4000 A
I_{TSM}	=	25×10^3 A
V_{TO}	=	2.1 V
r_T	=	0.58 m Ω
V_{Dclink}	=	2800 V

Features

- Patented free-floating silicon technology
- Low on-state and switching losses
- Annular gate electrode
- Industry standard housing
- Cosmic radiation withstand rating

Blocking

Symbols and parameters			Value			Unit
			min	typ	max	
V_{DRM}	Repetitive peak off-state voltage	$V_{GR} \geq 2$ V			4500	V
V_{RRM}	Repetitive peak reverse voltage				17	V
$V_{DC-link}$	Permanent DC voltage for 100 FIT failure rate	Ambient cosmic radiation at sea level in open air.			2800	V
I_{DRM}	Repetitive peak off-state current	$V_D = V_{DRM}, V_{GR} \geq 2$ V			100	mA
I_{RRM}	Repetitive peak reverse current	$V_R = V_{RRM}, R_{GK} = \infty \Omega$			50	mA

Mechanical data

Symbols and parameters			Value			Unit
			min	typ	max	
F_m	Mounting force		36	40	44	kN
D_p	Pole-piece diameter	± 0.1 mm		85		mm
H	Housing thickness		25.6		26.1	mm
m	Weight				1.5	kg
D_s	Surface creepage distance	Anode to Gate	33			mm
D_a	Air strike distance	Anode to Gate	14			mm

GTO Data

Symbols and parameters			Value			Unit
			min	typ	max	
$I_{T(AV)M}$	Max. average on-state current	Half sine wave, $T_C = 85^\circ\text{C}$			1000	A
$I_{T(RMS)}$	Max. RMS on-state current				1570	A
I_{TSM}	Max. peak non-repetitive surge current	$t_p = 10\text{ ms}$, $T_{vj} = 125^\circ\text{C}$, sine wave After Surge: $V_D = V_R = 0\text{ V}$			25×10^3	A
I^2t	Limiting load integral				3.1×10^6	A^2s
I_{TSM}	Max. peak non-repetitive surge current	$t_p = 1\text{ ms}$, $T_{vj} = 125^\circ\text{C}$, sine wave After Surge: $V_D = V_R = 0\text{ V}$			40×10^3	A
I^2t	Limiting load integral				800×10^3	A^2s
V_T	On-state voltage	$I_T = 4000\text{ A}$, $T_{vj} = 125^\circ\text{C}$			4.4	V
$V_{(TO)}$	Threshold voltage	$T_{vj} = 125^\circ\text{C}$ $I_T = 400 \dots 5000\text{ A}$			2.1	V
r_T	Slope resistance				0.58	$\text{m}\Omega$
I_H	Holding current	$T_{vj} = 25^\circ\text{C}$			100	A

Turn-on switching

Symbols and parameters				Value			Unit
				min	typ	max	
di_T/dt_{cr}	Critical rate of rise of on state current	$T_{vj} = 125^\circ\text{C}$, $I_T = 4000\text{ A}$, $I_{GM} = 50\text{ A}$, $di_G/dt = 40\text{ A}/\mu\text{s}$	$f = 200\text{ Hz}$		500	$\text{A}/\mu\text{s}$	
di_T/dt_{cr}	Critical rate of rise of on state current		$f = 1\text{ Hz}$		1000	$\text{A}/\mu\text{s}$	
t_{on}	Min. on-time	$V_D = 0.5 V_{DRM}$, $T_{vj} = 125^\circ\text{C}$, $I_T = 4000\text{ A}$, $di/dt = 300\text{ A}/\mu\text{s}$, $I_{GM} = 50\text{ A}$, $di_G/dt = 40\text{ A}/\mu\text{s}$, $C_S = 6\text{ }\mu\text{F}$, $R_S = 5\text{ }\Omega$		100		μs	
t_d	Turn-on delay time					2.5	μs
t_r	Rise time					5	μs
E_{on}	Turn-on energy per pulse					3.3	J

Turn-off switching

Symbols and parameters			Value			Unit
			min	typ	max	
I_{TGQM}	Max. controllable turn-off current	$V_{DM} \leq V_{DRM}$, $di_{GQ}/dt = 40 \text{ A}/\mu\text{s}$, $C_S = 6 \mu\text{F}$, $L_S \leq 0.3 \mu\text{H}$			4000	A
t_{off}	Min. off-time	$V_D = 0.5 V_{DRM}$, $T_{vj} = 125 \text{ }^\circ\text{C}$ $V_{DM} \leq V_{DRM}$, $di_{GQ}/dt = 40 \text{ A}/\mu\text{s}$, $I_{TGQ} = I_{TGQM}$, $R_S = 5 \Omega$, $C_S = 6 \mu\text{F}$, $L_S = 0.3 \mu\text{H}$	100			μs
t_s	Storage time				27	μs
t_f	Fall time				3	μs
E_{off}	Turn-on energy per pulse				14	J
I_{GQM}	Peak turn-off gate current				1100	A

Gate

Symbols and parameters			Value			Unit
			min	typ	max	
V_{GRM}	Repetitive peak reverse voltage			17	V	
I_{GRM}	Repetitive peak reverse current	$V_{GR} = V_{GRM}$			50	mA
V_{GT}	Gate trigger voltage	$T_{vj} = 25^\circ\text{C}$, $V_D = 24 \text{ V}$, $R_A = 0.1 \Omega$		1.2		V
I_{GT}	Gate trigger current			4		A

Thermal

Symbols and parameters			Value	Unit
T_{vj}	Junction operating temperature		-40 ... 125	$^\circ\text{C}$
T_{stg}	Storage temperature range		-40 ... 125	$^\circ\text{C}$
$R_{th(j-c)}$	Thermal resistance junction to case	Double side cooled	11	K/kW
$R_{th(j-c)A}$		Anode side cooled	20	K/kW
$R_{th(j-c)C}$		Cathode side cooled	25	K/kW
$R_{th(c-h)}$	Thermal resistance case to heatsink (Double side cooled)	Single side cooled	6	K/kW
$R_{th(c-h)}$		Double side cooled	3	K/kW

DIMENSIONS

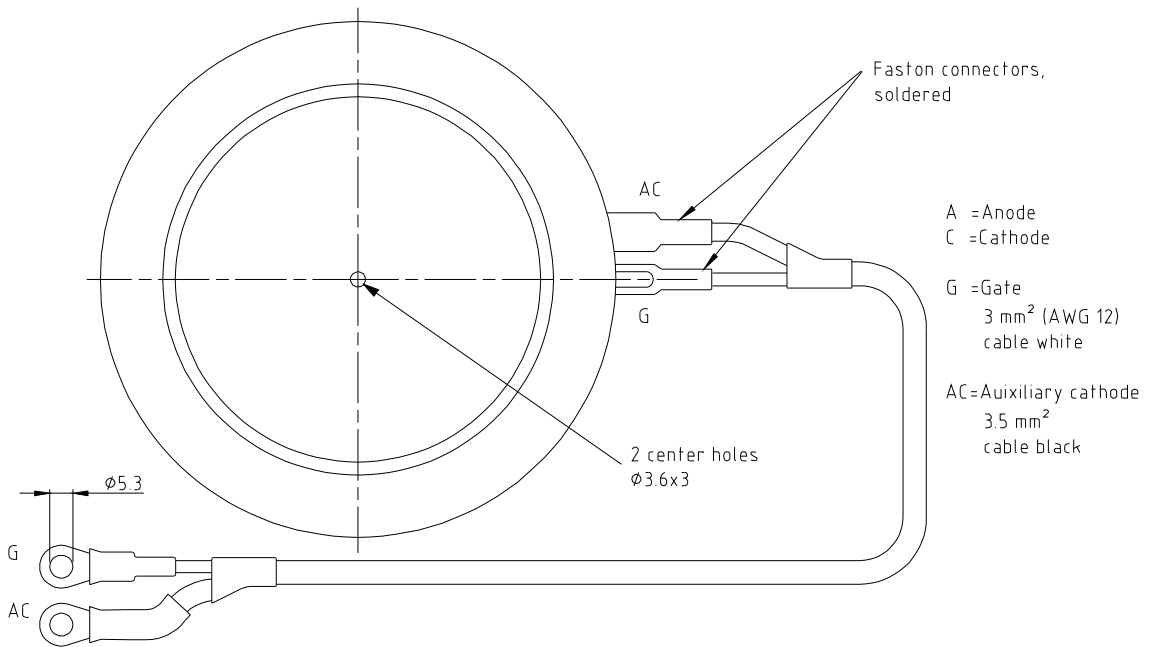
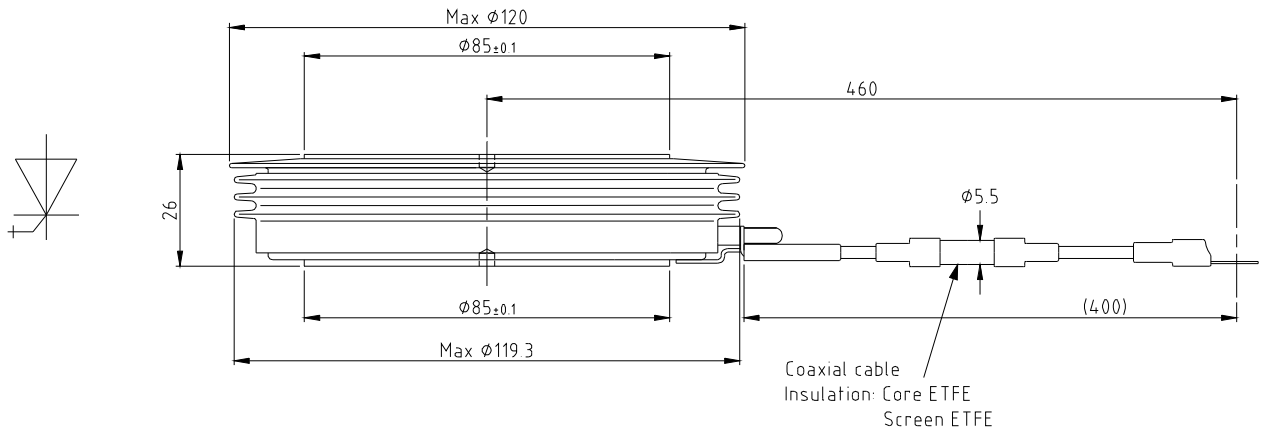

Analytical function for transient thermal impedance:

$$Z_{th(j-c)}(t) = \sum_{i=1}^n R_i(1 - e^{-t/\tau_i})$$

i	1	2	3	4
$R_i(K/kW)$	7.313	1.974	1.218	0.501
$\tau_i(s)$	0.5400	0.0939	0.0117	0.0036

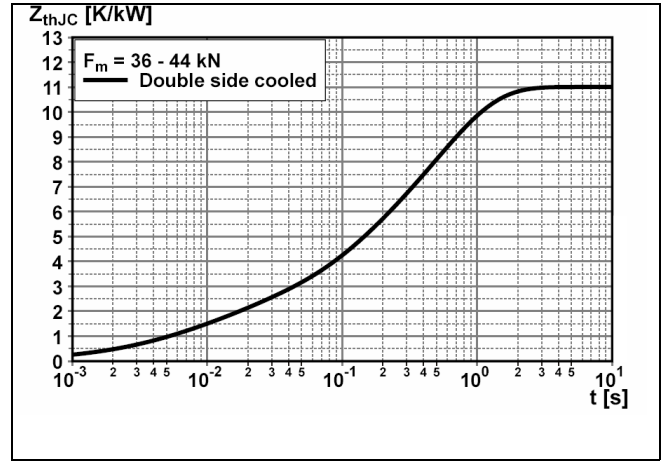

Fig. 1 Transient thermal impedance, junction to case

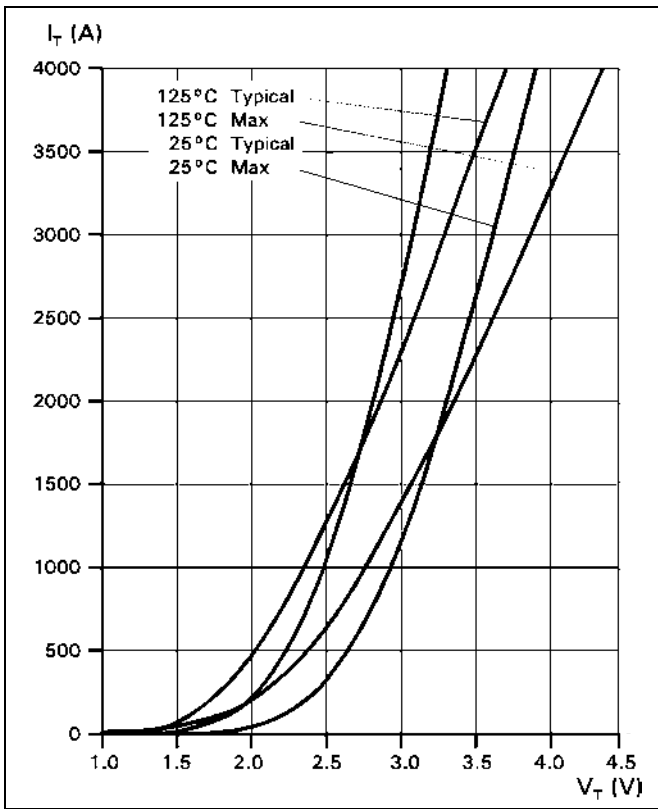

Fig. 2 On-state characteristics

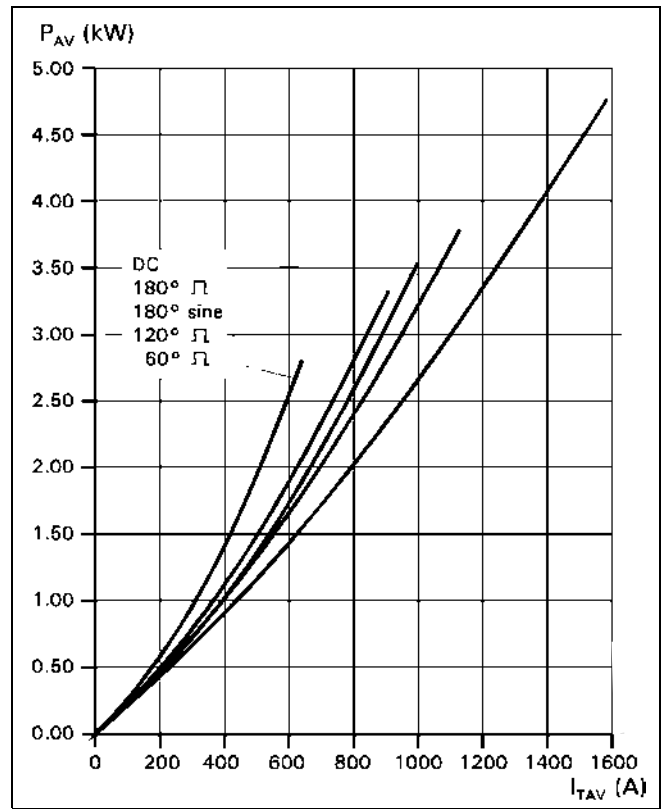

Fig. 3 Average on-state power dissipation vs. average on-state current

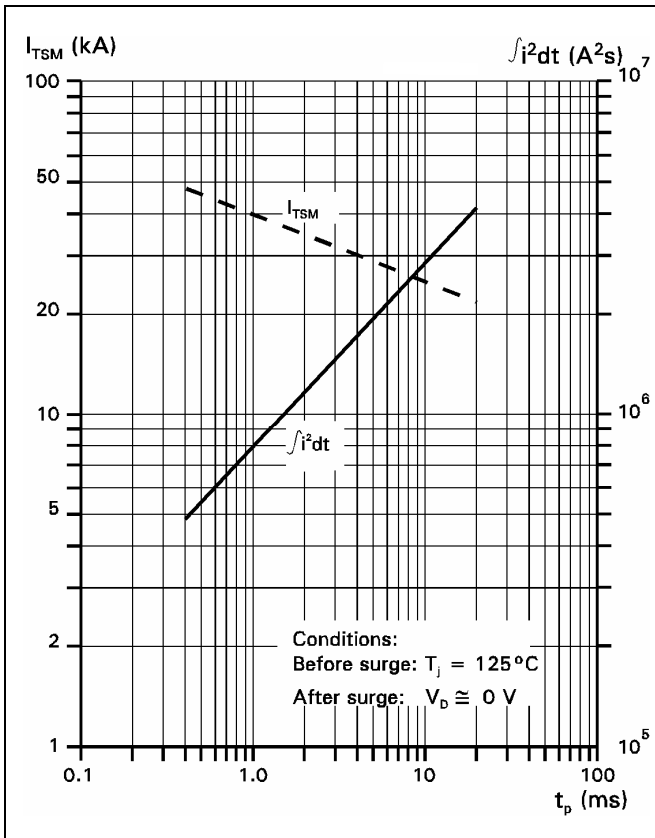

Fig. 4 Surge current and fusing integral vs. pulse width

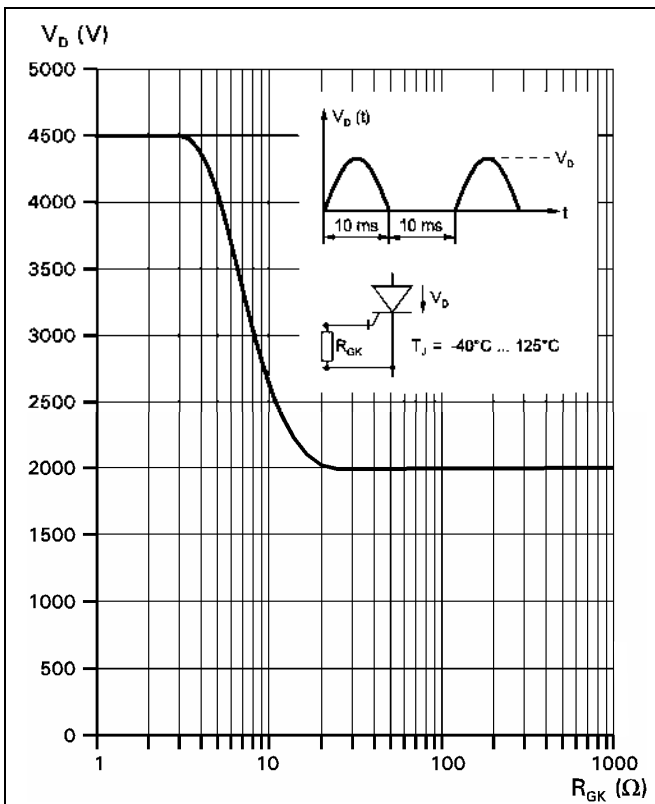

Fig. 5 Forward blocking voltage vs. gate-cathode resistance

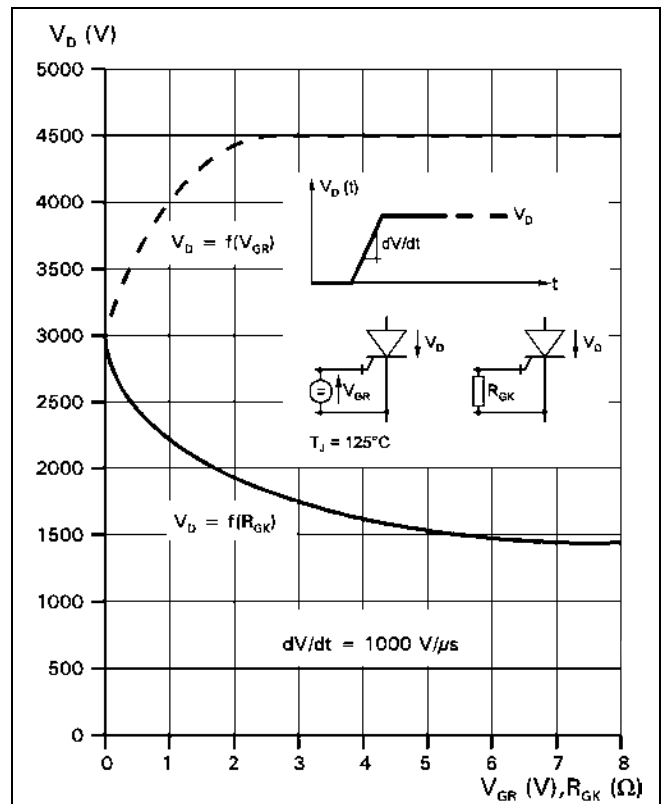

Fig. 6 Static dv/dt capability; forward blocking voltage vs. neg. gate voltage or gate cathode resistance

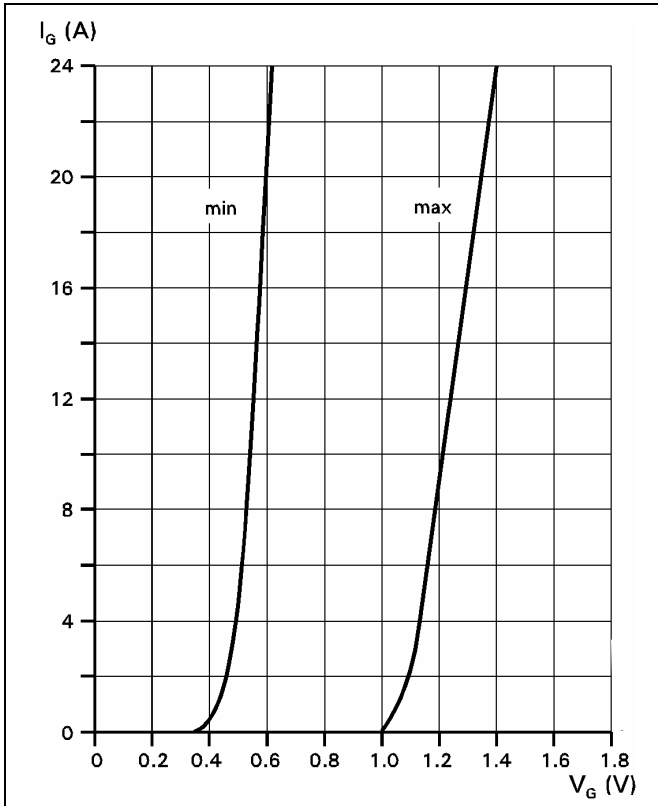

Fig. 7 Forward gate current vs. forward gate voltage

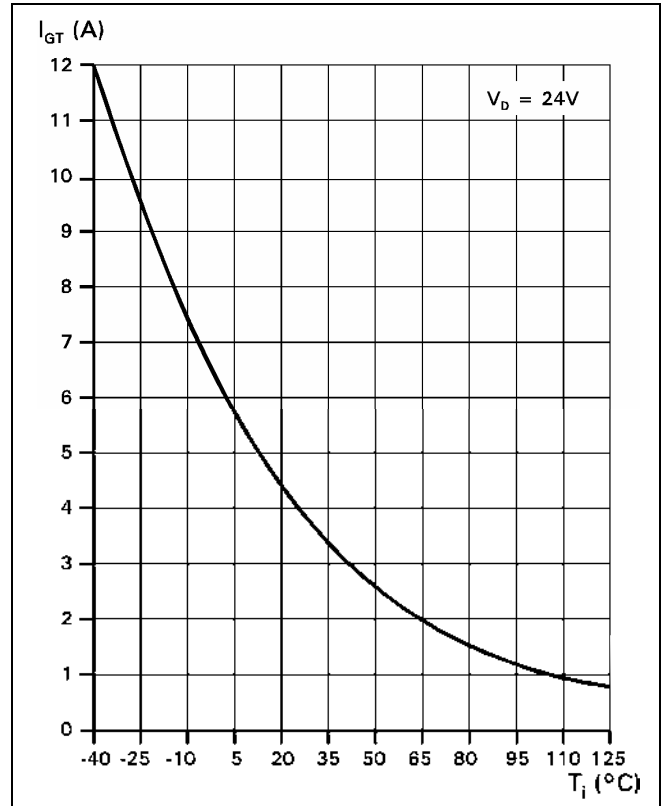

Fig. 8 Gate trigger current vs. junction temperature

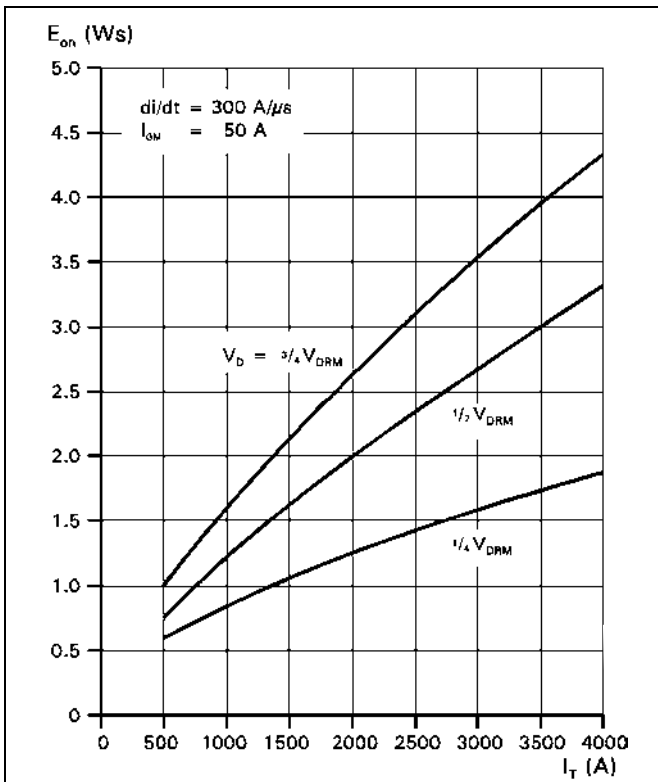

Fig. 9 Turn-on energy per pulse vs. on-state current and turn-on voltage

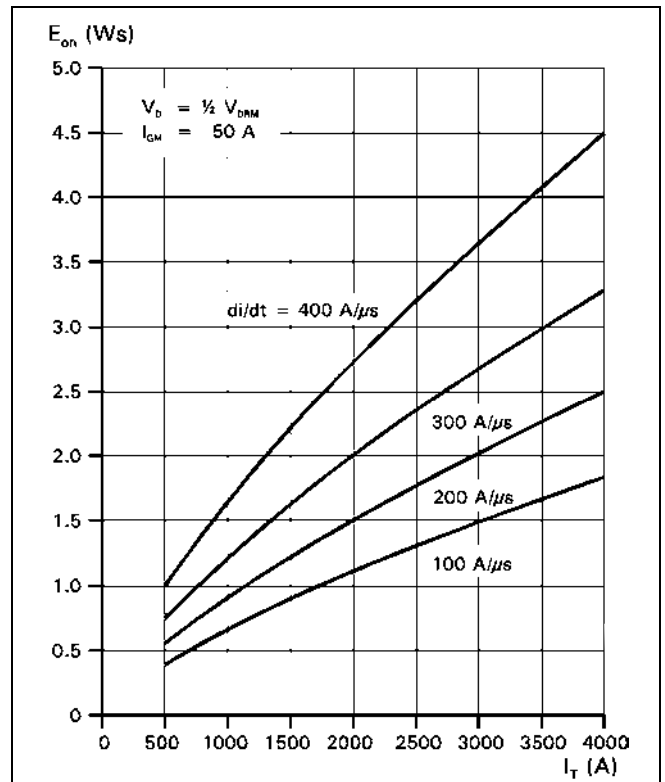

Fig. 10 Turn-on energy per pulse vs. on-state current and current rise rate

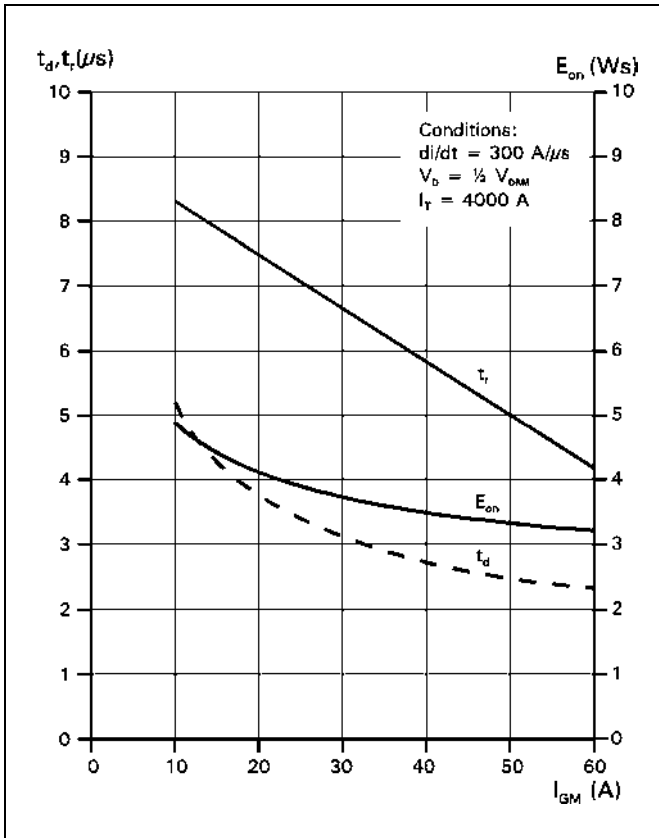

Fig. 11 Turn-on energy per pulse vs. on-state current and turn-on voltage

Common Test conditions:

- $di_G/dt = 40 \text{ A}/\mu\text{s}$
- $C_S = 6 \mu\text{F}$
- $R_S = 5 \Omega$
- $T_j = 125^\circ\text{C}$

Definition of Turn-on energy:

$$E_{on} = \int_0^{20 \text{ ms}} V_D \cdot I_T dt \quad (t=0, I_G = 0.1 \cdot I_{GM})$$

Definition of Turn-off energy:

$$E_{off} = \int_0^{40 \text{ ns}} V_D \cdot I_T dt \quad (t=0, I_r = 0.9 \cdot I_{rGQ})$$

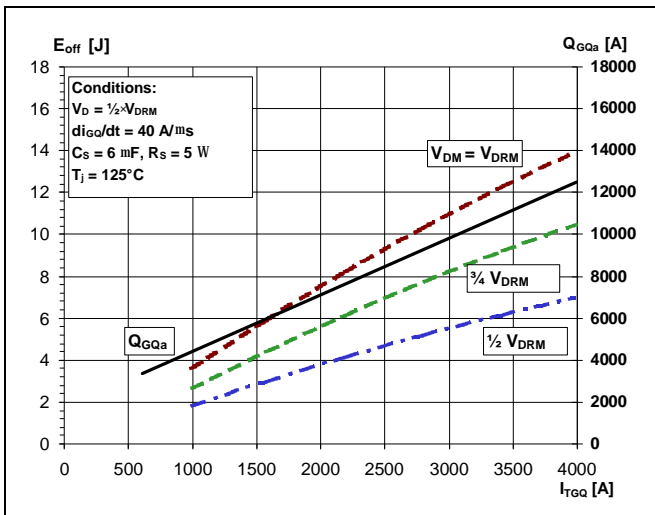

Fig. 12 Turn-off energy per pulse vs. turn-off current and peak turn-off voltage, extracted gate charge vs. turn-off current

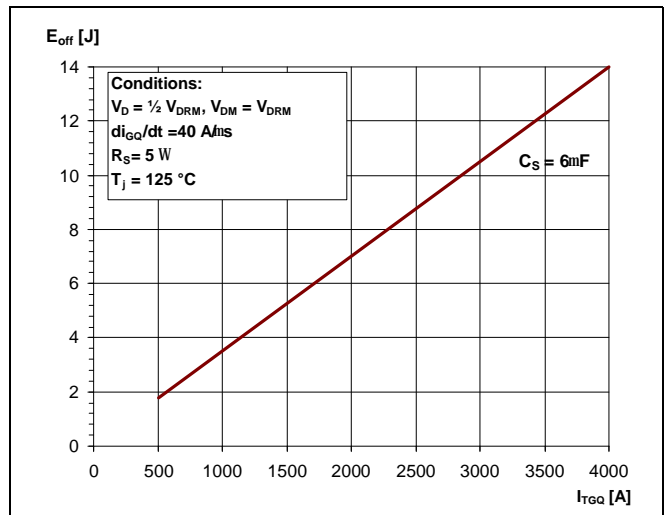

Fig. 13 Turn-off energy per pulse vs. turn-off current and snubber capacitance

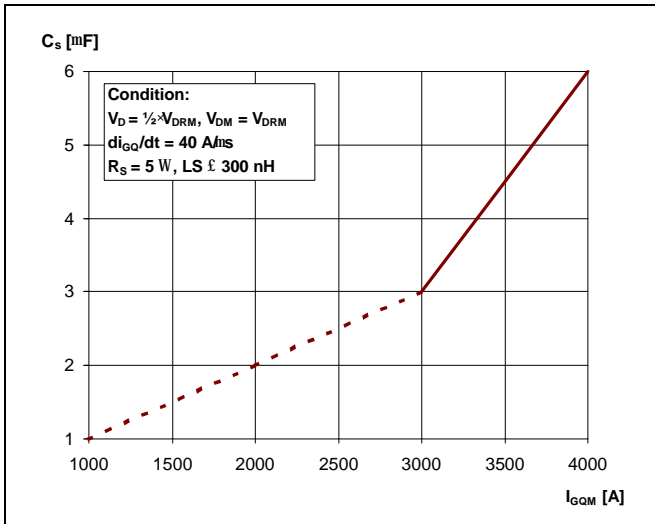

Fig. 14 Required snubber capacitor vs. max allowable turn-off current

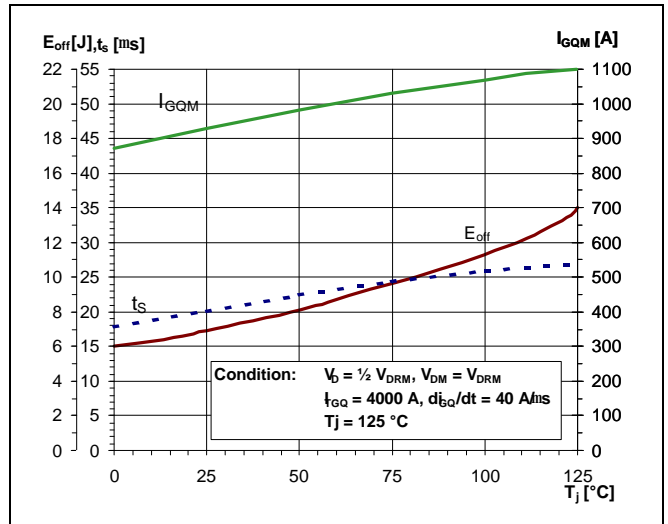

Fig. 15 Turn-off energy per pulse, storage time and peak turn-off gate current vs. junction temperature

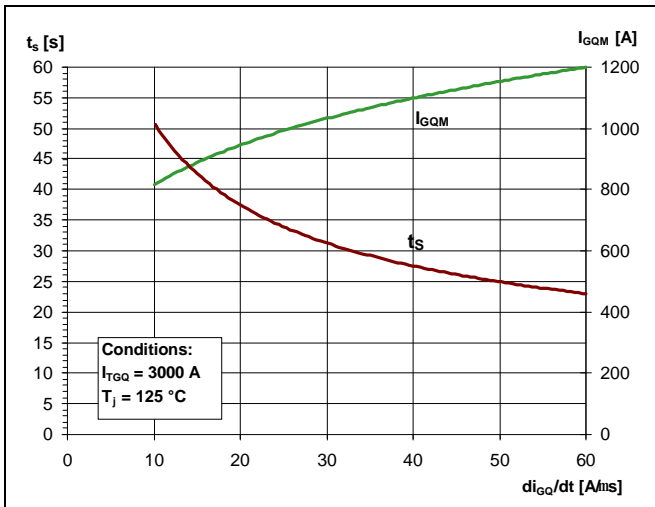

Fig. 16 Storage time and peak turn-off gate current vs. neg. gate current rise rate

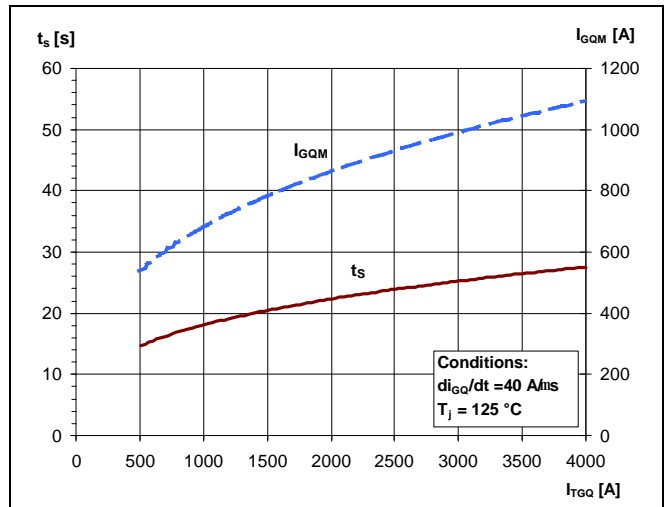

Fig. 17 Storage time and peak turn-off gate current vs. turn-off current

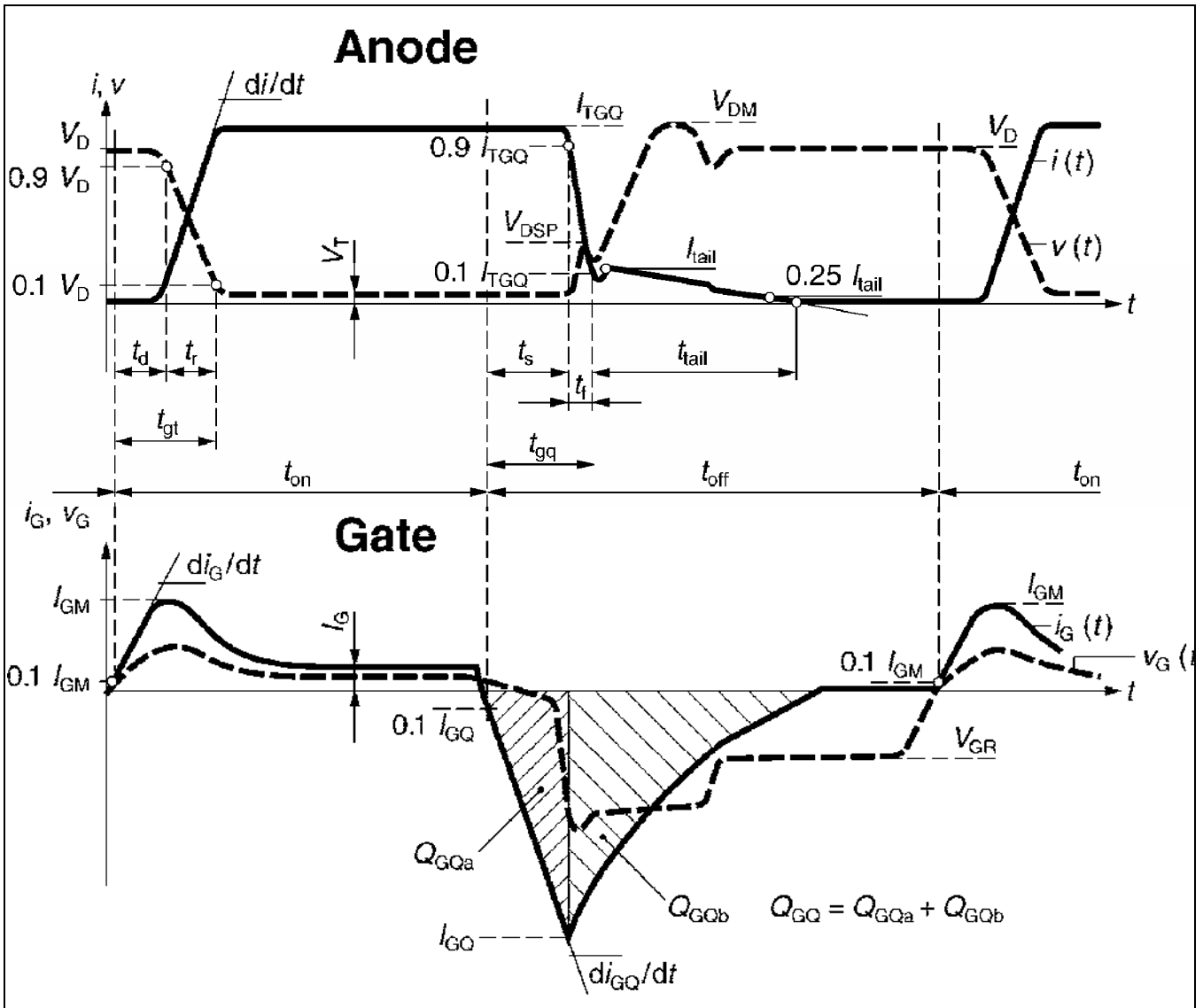

Fig. 18 General current and voltage waveforms with GTO-specific symbols