

Thyristor

AGA 2500-25-H-01



Key Parameters

V_{DRM}	=	2500 V
I_{TGQM}	=	2500 A
I_{TSM}	=	16 kA
V_{TO}	=	1.66 V
r_T	=	0.57 mΩ
V_{Dclink}	=	1400 V

Features

- Patented free-floating silicon technology
- Low on-state and switching losses
- Annular gate electrode
- Industry standard housing
- Cosmic radiation withstand rating

Blocking

Symbols and parameters			Value			Unit
			min	typ	max	
V_{DRM}	Repetitive peak off-state voltage	$V_{GR} \geq 2 \text{ V}$			2500	V
V_{RRM}	Repetitive peak reverse voltage				17	V
$V_{DC-link}$	Permanent DC voltage for 100 FIT failure rate	$-40 \leq T_j \leq 125 \text{ °C}$. Ambient cosmic radiation at sea level in open air.			1400	V
I_{DRM}	Repetitive peak off-state current	$V_D = V_{DRM}, V_{GR} \geq 2 \text{ V}$			30	mA
I_{RRM}	Repetitive peak reverse current	$V_R = V_{RRM}, R_{GK} = \infty$			50	mA

Mechanical data

Symbols and parameters			Value			Unit
			min	typ	max	
F_m	Mounting force		17		24	kN
A	Acceleration: Device unclamped Device clamped				50 200	m/s ²
m	Weight				0.8	kg
D_s	Surface creepage distance		22			mm
D_a	Air strike distance		13			mm

GTO Data

Symbols and parameters				Value			Unit
				min	typ	max	
$I_{T(AV)M}$	Max. average on-state current	Half sine wave, $T_C = 85\text{ }^\circ\text{C}$				830	A
$I_{T(RMS)}$	Max. RMS on-state current					1300	kA
I_{TSM}	Max. peak non-repetitive surge current	$t_p = 10\text{ ms}$ $t_p = 1\text{ ms}$	$T_j = 125\text{ }^\circ\text{C}$ After surge: $V_D = V_R = 0\text{V}$			16 32	kA
I^2t	Limiting load integral	$t_p = 10\text{ ms}$ $t_p = 1\text{ ms}$				1.28×10^6 0.51×10^6	A^2s
V_T	On-state voltage	$I_T = 2500\text{ A}$				3.1	V
$V_{(TO)}$	Threshold voltage	$I_T = 200\text{-}3000$	$T_j = 125\text{ }^\circ\text{C}$			1.66	V
r_T	Slope resistance	3000 A				0.57	$\text{m}\Omega$
I_H	Holding current	$T_j = 25\text{ }^\circ\text{C}$				50	A

Turn-on switching

Symbols and parameters				Value			Unit
				min	typ	max	
di_T/dt_{cr}	Critical rate of rise of on state current	$I_T = 2500\text{ A},$ $T_j = 125\text{ }^\circ\text{C}$ $I_{GM} = 30\text{ A},$ $di_G/dt = 20\text{ A}/\mu\text{s}$	$f = 200\text{ Hz}$			400	$\text{A}/\mu\text{s}$
			$f = 1\text{ Hz}$			700	$\text{A}/\mu\text{s}$
$t_{on(min)}$	Min. on-time	$V_D = 0.5 V_{DRM},$ $T_{vj} = 125\text{ }^\circ\text{C},$ $I_T = 2500\text{ A},$ $di/dt = 200\text{ A}/\mu\text{s},$ $I_{GM} = 30\text{ A},$ $di_G/dt = 20\text{ A}/\mu\text{s},$ $C_S = 6\text{ }\mu\text{F}, R_S = 5\text{ }\Omega$		120			μs
t_d	Delay time					1.5	μs
t_r	Rise time					3.5	μs
E_{on}	Turn-on energy per pulse					0.85	J

Turn-off switching

Symbols and parameters			Value			Unit
			min	typ	max	
I_{TGQM}	Max. controllable turn-off current	$V_{DM} = V_{DRM}$, $di_{GQ}/dt = 30 \text{ A}/\mu\text{s}$, $C_S = 6 \mu\text{F}$, $L_S \leq 0.3 \mu\text{H}$			2500	A
t_{off}	Min. off-time	$V_D = 0.5 V_{DRM}$, $T_{vj} = 125 \text{ }^\circ\text{C}$ $V_{DM} = V_{DRM}$, $di_{GQ}/dt = 30 \text{ A}/\mu\text{s}$, $I_{TGQ} = I_{TGQM}$, $R_S = 5 \Omega$, $C_S = 6 \mu\text{F}$, $L_S \leq 0.3 \mu\text{H}$	80			μs
t_s	Storage time				24	μs
t_f	Fall time				2	μs
E_{off}	Turn-on energy per pulse				3.5	J
I_{GQM}	Peak turn-off gate current				700	A

Gate

Symbols and parameters			Value			Unit
			min	typ	max	
V_{GRM}	Repetitive peak reverse voltage				17	V
I_{GRM}	Repetitive peak reverse current	$V_{GR} = V_{GRM}$			50	mA
V_{GT}	Gate trigger voltage	$T_{vj} = 25 \text{ }^\circ\text{C}$, $V_D = 24 \text{ V}$, $R_A = 0.1 \Omega$		1.0		V
I_{GT}	Gate trigger current			2.5		A

Thermal

Symbols and parameters			Value	Unit
T_j	Junction operating temperature		-40 ... 125	$^\circ\text{C}$
R_{thJC}	Thermal resistance junction to case	Anode side cooled	30	K/kW
		Cathode side cooled	39	K/kW
		Double side cooled	17	K/kW
R_{thCH}	Thermal resistance case to heatsink (Double side cooled)	Single side cooled	10	K/kW
		Double side cooled	5	K/kW

DIMENSIONS

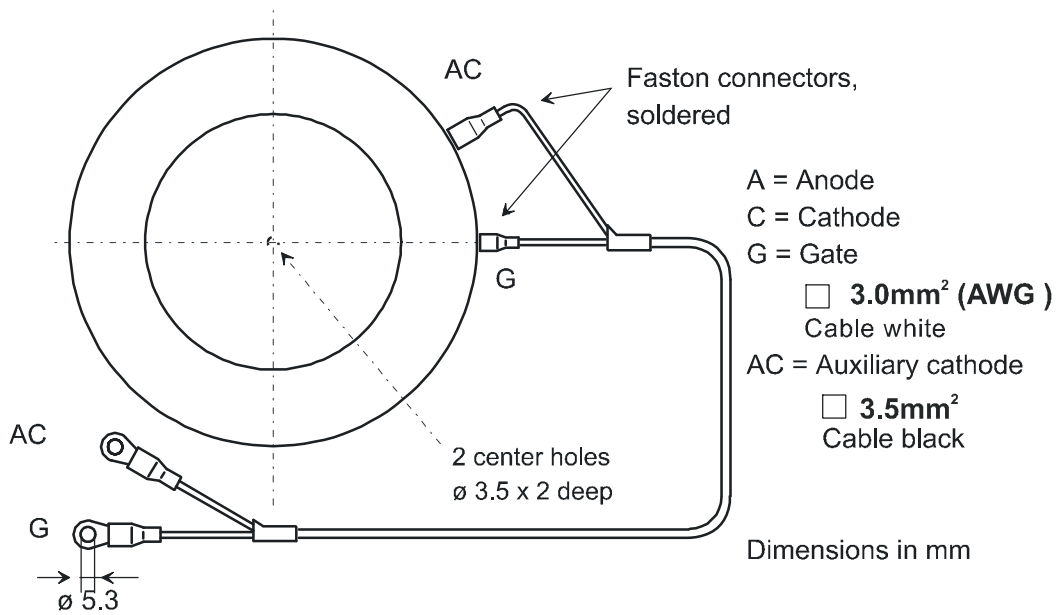
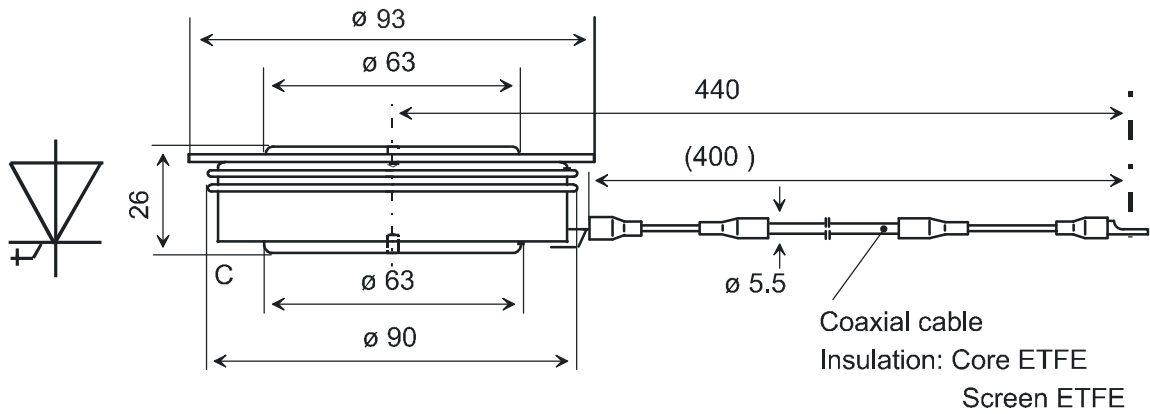

Analytical function for transient thermal impedance:

$$Z_{thJC}(t) = \sum_{i=1}^4 R_i (1 - e^{-t/\tau_i})$$

i	1	2	3	4
R _i (K/kW)	11.7	4.7	0.64	0.0001
τ _i (s)	0.9	0.26	0.002	0.001

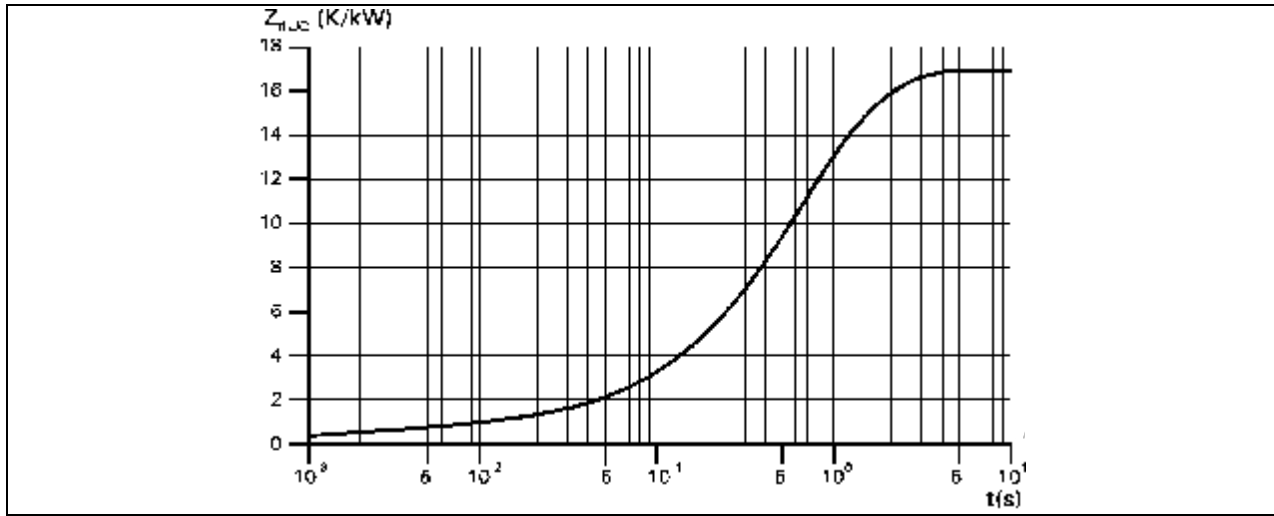

Fig. 1 Transient thermal impedance, junction to case.

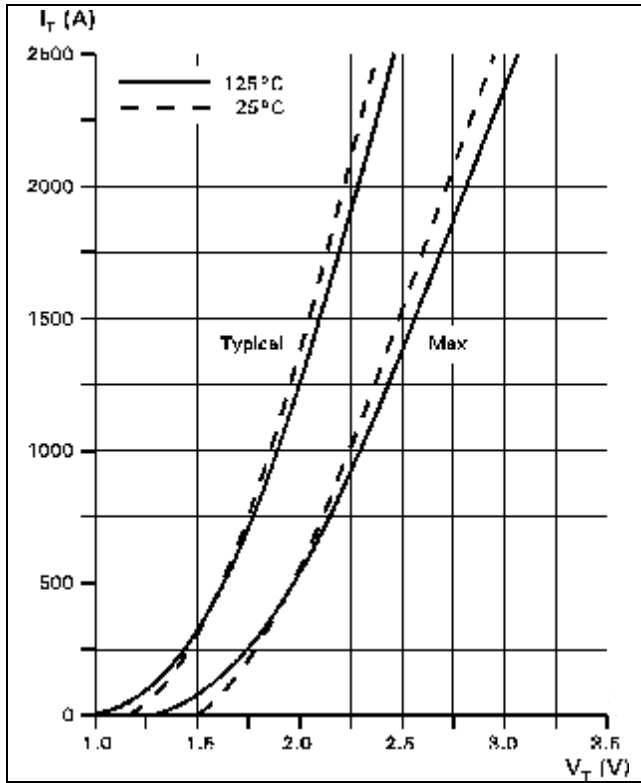

Fig. 2 On-state characteristics

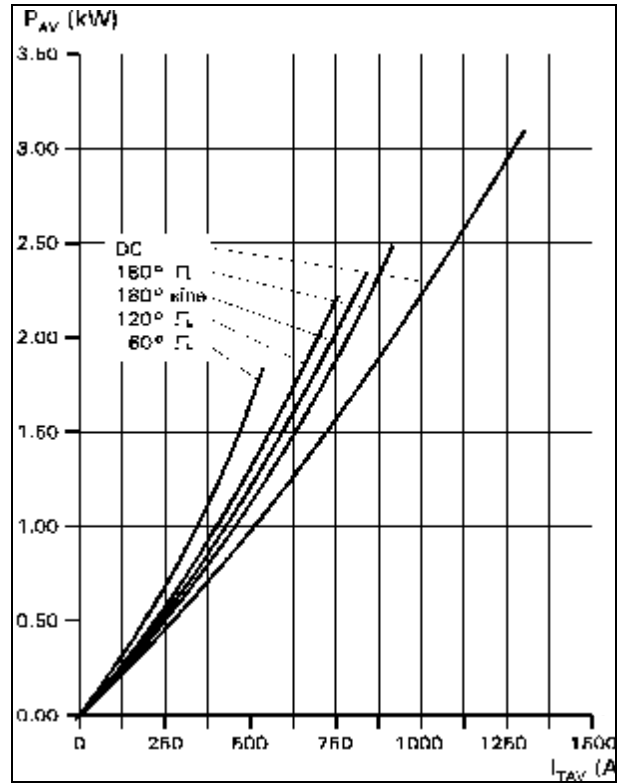

Fig. 3 Average on-state power dissipation vs. average on-state current.

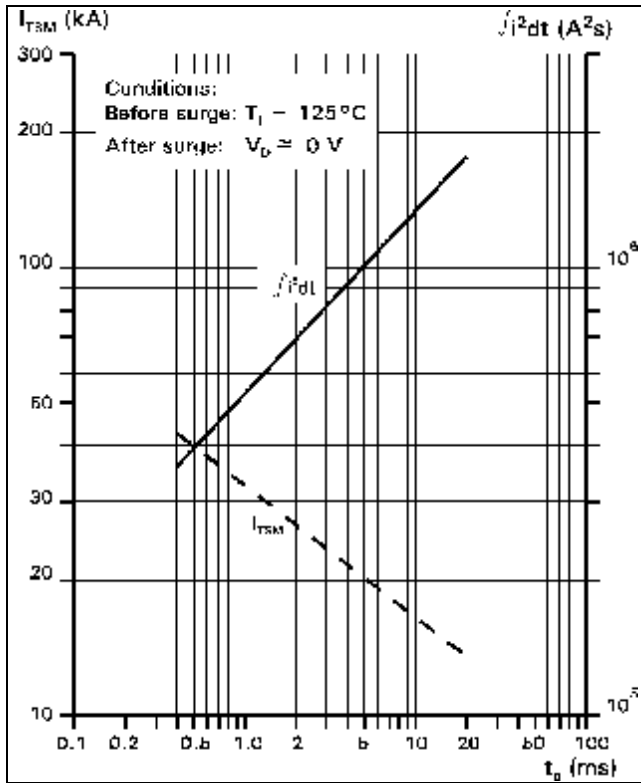

Fig. 4 Surge current and fusing integral vs. pulse width

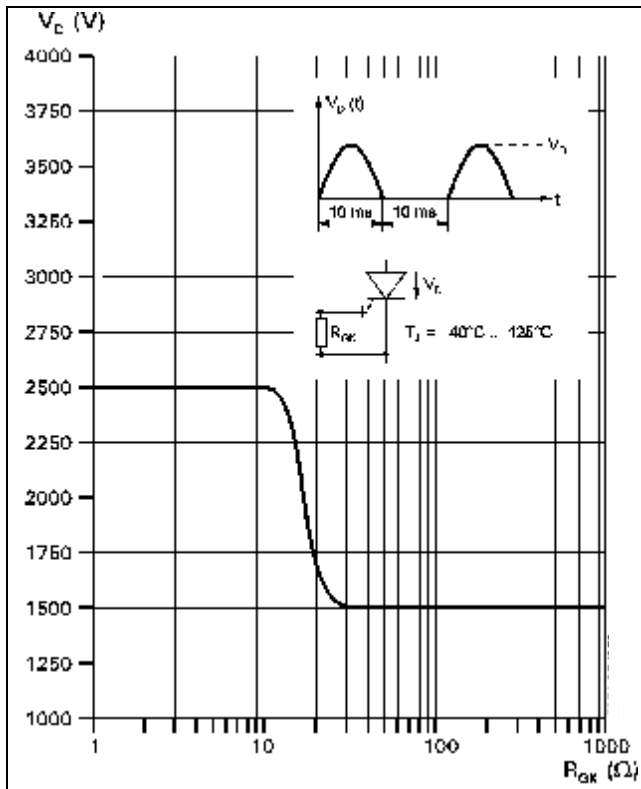

Fig. 5 Forward blocking voltage vs. gate-cathode resistance.

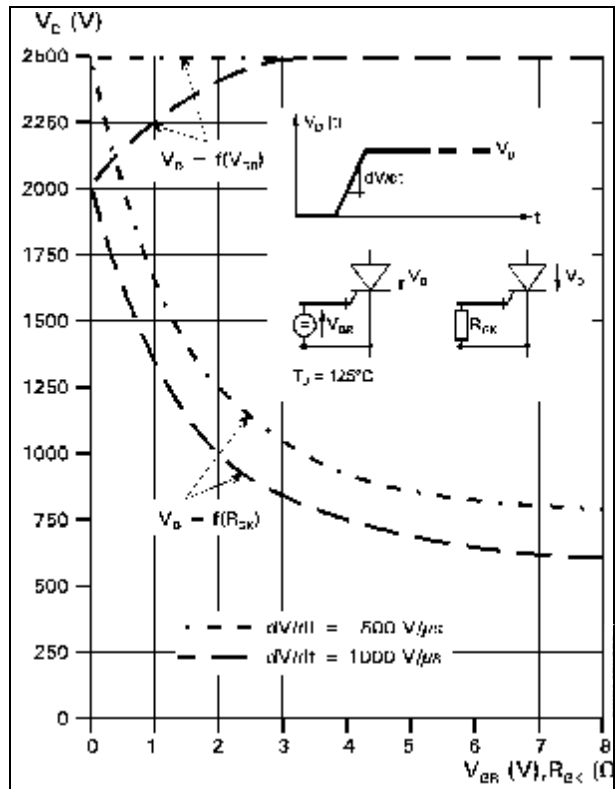

Fig. 6 Static dv/dt capability: Forward blocking voltage vs. neg. gate voltage or gate cathode resistance.

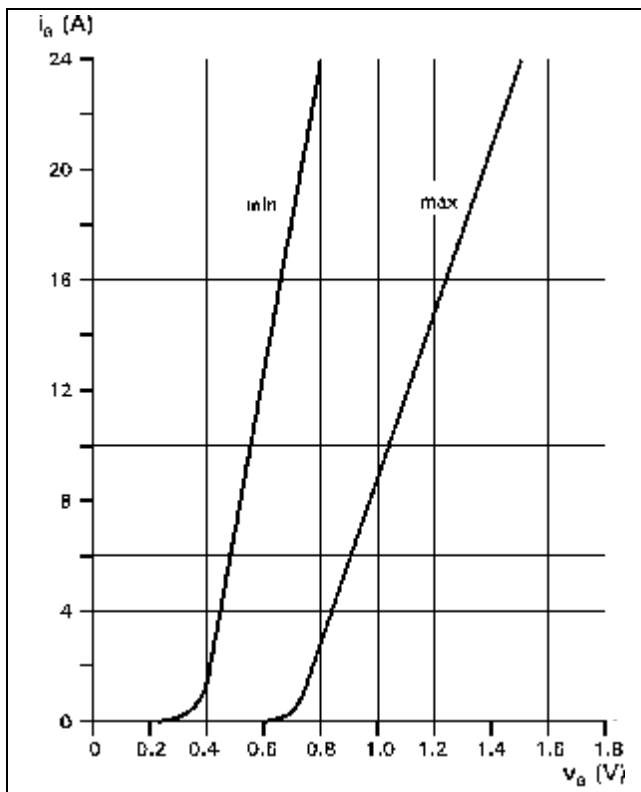

Fig. 7 Forward gate current vs. forward gate voltage.

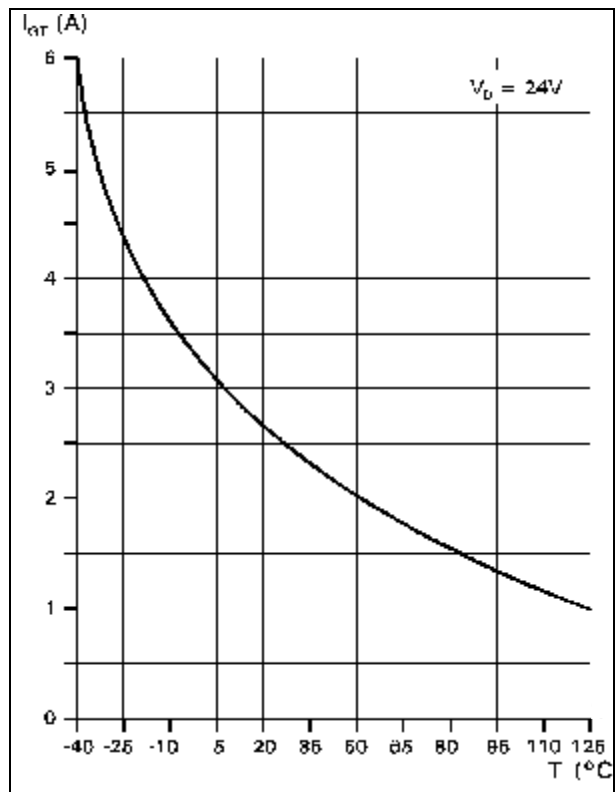

Fig. 8 Gate trigger current vs. junction temperature

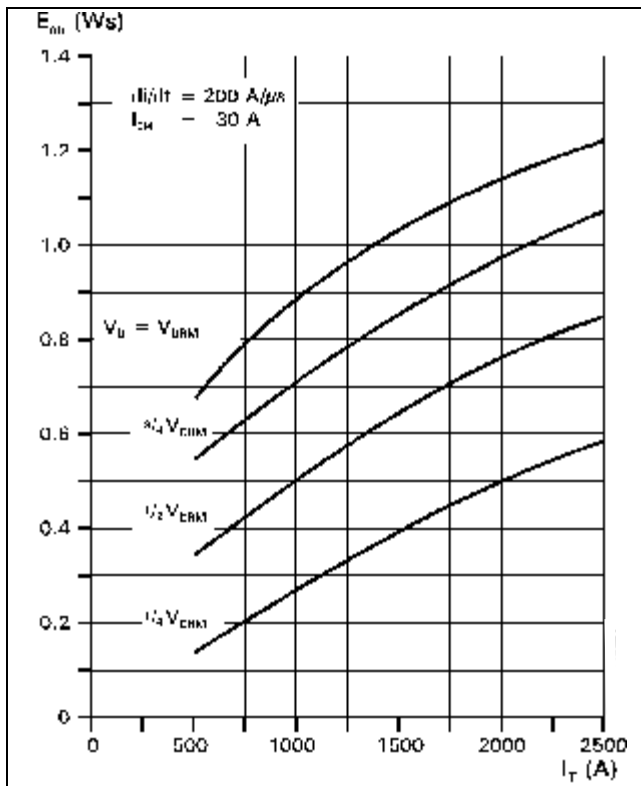

Fig. 9 Turn-on energy per pulse vs. on-state current and turn-on voltage.

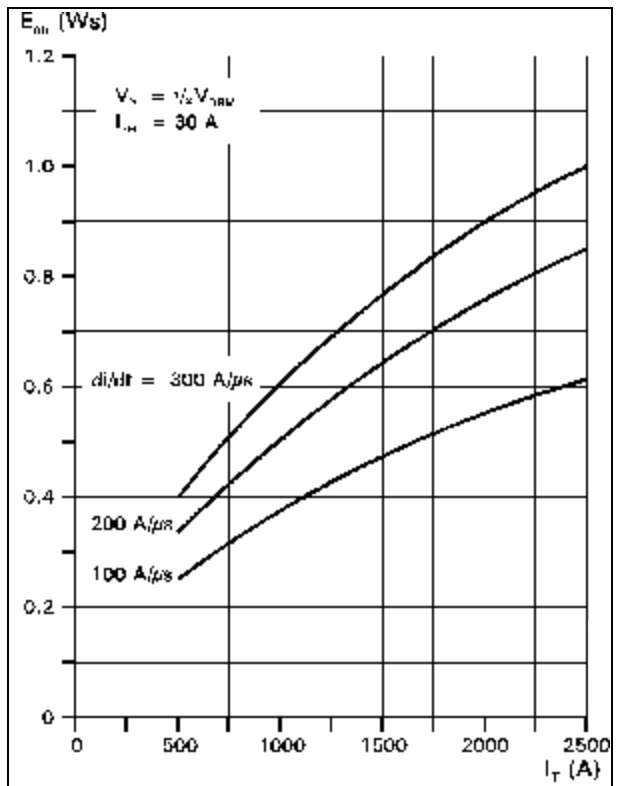

Fig. 10 Turn-on energy per pulse vs. on-state current and current rise rate

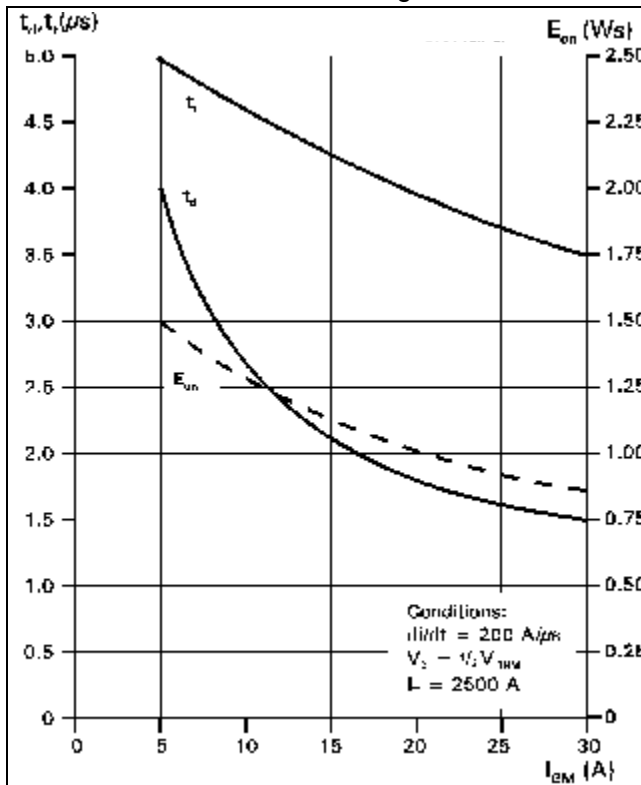

Fig. 11 Turn-on energy per pulse vs. on-state current and turn-on voltage.

Common Test conditions for figures 9, 10 and 11:

- $di_G/dt = 20 \text{ A}/\mu\text{s}$
- $C_S = 6 \mu\text{F}$
- $R_S = 5 \Omega$
- $T_j = 125 \text{ }^\circ\text{C}$

Definition of Turn-on energy:

$$E_{on} = \int_0^{20 \text{ ms}} V_D \cdot I_T dt \quad (t=0, I_G = 0.1 \cdot I_{GM})$$

Common Test conditions for figures 12, 13 and 15:

Definition of Turn-off energy:

$$E_{off} = \int_0^{40 \text{ ms}} V_D \cdot I_T dt \quad (t=0, I_T = 0.9 \cdot I_{TQ})$$

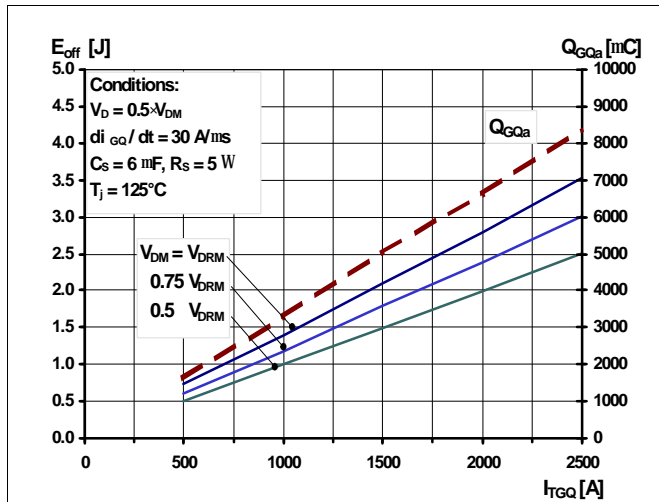

Fig. 12 Turn-off energy per pulse vs. turn-off current and peak turn-off voltage. Extracted gate charge vs. turn-off current.

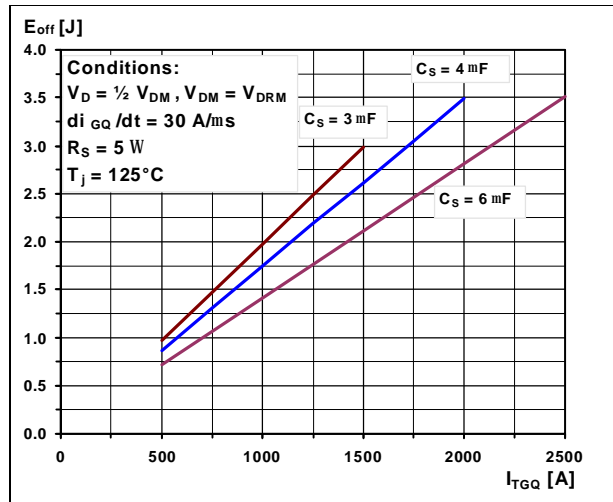

Fig. 13 Turn-off energy per pulse vs. turn-off current and snubber capacitance.

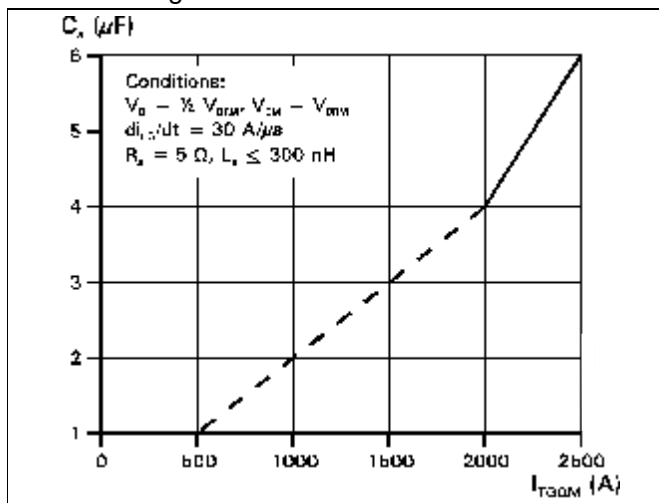

Fig. 14 Required snubber capacitor vs. max allowable turn-off current.

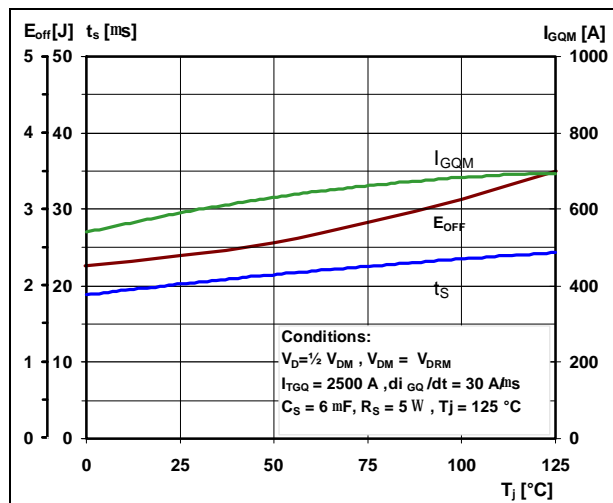

Fig. 15 Turn-off energy per pulse, storage time and peak turn-off gate current vs. junction temperature

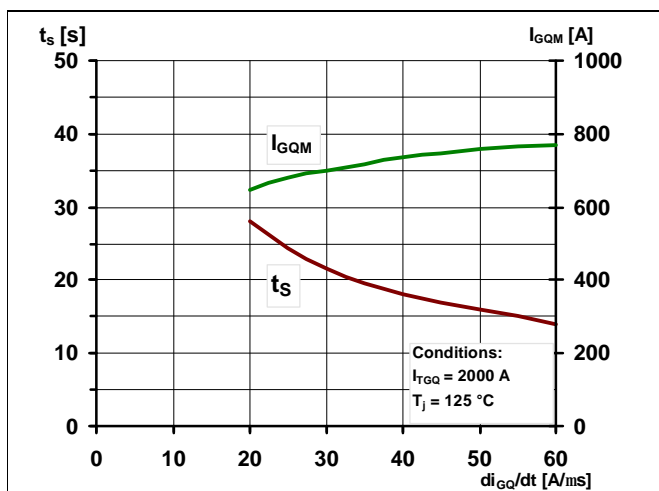

Fig. 16 Storage time and peak turn-off gate current vs. neg. gate current rise rate.

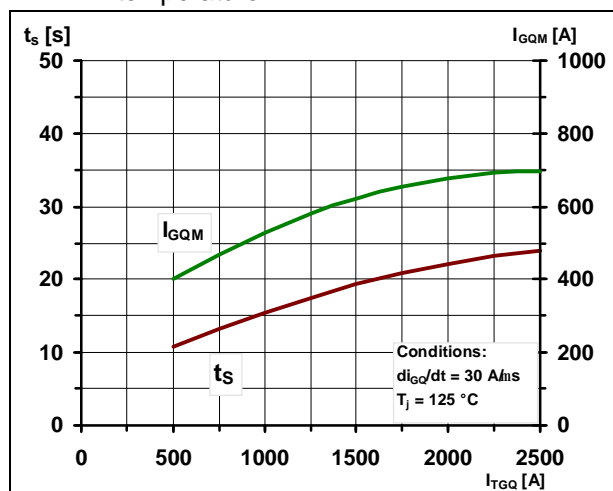

Fig. 17 Storage time and peak turn-off gate current vs. turn-off current

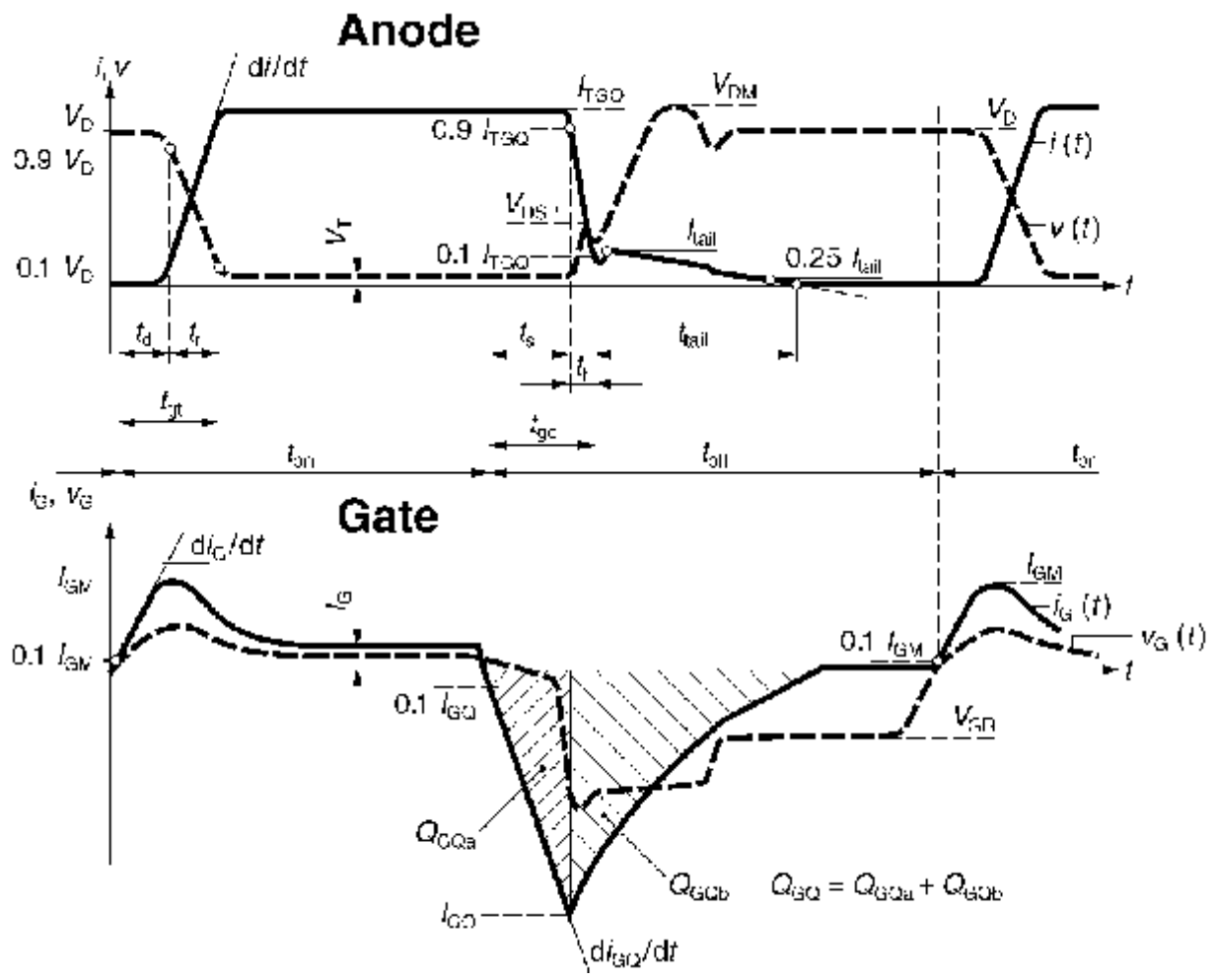

Fig. 18 General current and voltage waveforms with GTO-specific symbols