

Thyristor

AGA 1500-25-F-02



Key Parameters

| | | |
|--------------|---|--------------------|
| V_{DRM} | = | 2500 V |
| I_{TGQM} | = | 1500 A |
| I_{TSM} | = | 10×10^3 A |
| V_{T0} | = | 1.45 V |
| r_T | = | 0.90 m Ω |
| V_{Dclink} | = | 1400 V |

Features

- Patented free-floating silicon technology
- Low on-state and switching losses
- Annular gate electrode
- Industry standard housing
- Cosmic radiation withstand rating

Blocking

| Symbols and parameters | | | Value | | | Unit |
|------------------------|---|--|-------|-----|------|------|
| | | | min | typ | max | |
| V_{DRM} | Repetitive peak off-state voltage | $V_{GR} \geq 2$ V | | | 2500 | V |
| V_{RRM} | Repetitive peak reverse voltage | | | | 17 | V |
| $V_{DC-link}$ | Permanent DC voltage for 100 FIT failure rate | Ambient cosmic radiation at sea level in open air. | | | 1400 | V |
| I_{DRM} | Repetitive peak off-state current | $V_D = V_{DRM}, V_{GR} \geq 2$ V | | | 100 | mA |
| I_{RRM} | Repetitive peak reverse current | $V_R = V_{RRM}, R_{GK} = \infty \Omega$ | | | 50 | mA |

Mechanical data

| Symbols and parameters | | | Value | | | Unit |
|------------------------|---------------------------|---------------|-------|-----|------|------|
| | | | min | typ | max | |
| F_m | Mounting force | | 14 | 15 | 16 | kN |
| D_p | Pole-piece diameter | ± 0.1 mm | | 47 | | mm |
| H | Housing thickness | | 25.8 | | 26.2 | mm |
| m | Weight | | | | 0.6 | kg |
| D_s | Surface creepage distance | Anode to Gate | 25 | | | mm |
| D | Air strike distance | Anode to Gate | 15 | | | mm |

GTO Data

| Symbols and parameters | | | Value | | | Unit |
|------------------------|--|--|-------|-----|-------------------|----------------------|
| | | | min | typ | max | |
| $I_{T(AV)M}$ | Max. average on-state current | Half sine wave, $T_C = 85^\circ\text{C}$ | | | 570 | A |
| $I_{T(RMS)}$ | Max. RMS on-state current | | | | 900 | A |
| I_{TSM} | Max. peak non-repetitive surge current | $t_p = 10\text{ ms}$, $T_{vj} = 125^\circ\text{C}$, sine wave After Surge: $V_D = V_R = 0\text{ V}$ | | | 10×10^3 | A |
| I^2t | Limiting load integral | | | | 500×10^3 | A^2s |
| I_{TSM} | Max. peak non-repetitive surge current | $t_p = 1\text{ ms}$, $T_{vj} = 125^\circ\text{C}$, sine wave After Surge: $V_D = V_R = 0\text{ V}$ | | | 20×10^3 | A |
| I^2t | Limiting load integral | | | | 200×10^3 | A^2s |
| V_T | On-state voltage | $I_T = 1500\text{ A}$, $T_{vj} = 125^\circ\text{C}$ | | | 2.8 | V |
| $V_{(TO)}$ | Threshold voltage | $T_{vj} = 125^\circ\text{C}$ $I_T = 300 \dots 2000\text{ A}$ | | | 1.45 | V |
| r_T | Slope resistance | | | | 0.90 | $\text{m}\Omega$ |
| I_H | Holding current | $T_{vj} = 25^\circ\text{C}$ | | | 50 | A |

Turn-on switching

| Symbols and parameters | | | | Value | | | Unit |
|------------------------|---|--|---------------------|-------|-----|------------------------|------|
| | | | | min | typ | max | |
| di_T/dt_{cr} | Critical rate of rise of on state current | $T_{vj} = 125^\circ\text{C}$, $I_T = 1500\text{ A}$, $I_{GM} = 30\text{ A}$, $di_G/dt = 20\text{ A}/\mu\text{s}$ | $f = 200\text{ Hz}$ | | 400 | $\text{A}/\mu\text{s}$ | |
| di_T/dt_{cr} | Critical rate of rise of on state current | | $f = 1\text{ Hz}$ | | 600 | $\text{A}/\mu\text{s}$ | |
| t_{on} | Min. on-time | $V_D = 0.5 V_{DRM}$, $T_{vj} = 125^\circ\text{C}$ $I_T = 1500\text{ A}$, $di/dt = 100\text{ A}/\mu\text{s}$, $I_{GM} = 30\text{ A}$, $di_G/dt = 20\text{ A}/\mu\text{s}$, $C_S = 3\text{ }\mu\text{F}$, $R_S = 5\text{ }\Omega$ | | 80 | | μs | |
| t_d | Turn-on delay time | $V_D = 0.5 V_{DRM}$, $T_{vj} = 125^\circ\text{C}$ $I_T = 1500\text{ A}$, $di/dt = 100\text{ A}/\mu\text{s}$, $I_{GM} = 30\text{ A}$, $di_G/dt = 20\text{ A}/\mu\text{s}$, $C_S = 3\text{ }\mu\text{F}$, $R_S = 5\text{ }\Omega$ | | | 2 | μs | |
| t_r | Rise time | | | | 4 | μs | |
| E_{on} | Turn-on energy per pulse | | | | 0.5 | J | |

Turn-off switching

| Symbols and parameters | | | Value | | | Unit |
|------------------------|------------------------------------|--|-------|-----|------|---------------|
| | | | min | typ | max | |
| I_{TGQM} | Max. controllable turn-off current | $V_{DM} \leq V_{DRM}$, $di_{GQ}/dt = 30 \text{ A}/\mu\text{s}$, $C_S = 3 \mu\text{F}$, $L_S \leq 0.3 \mu\text{H}$ | | | 1500 | A |
| t_{off} | Min. off-time | $V_D = 0.5 V_{DRM}$, $T_{vj} = 125 \text{ }^\circ\text{C}$ $V_{DM} \leq V_{DRM}$, $di_{GQ}/dt = 30 \text{ A}/\mu\text{s}$, $I_{TGQ} = I_{TGQM}$, $R_S = 5 \Omega$, $C_S = 3 \mu\text{F}$, $L_S = 0.3 \mu\text{H}$ | 80 | | | μs |
| t_s | Storage time | $V_D = 0.5 V_{DRM}$, $T_{vj} = 125 \text{ }^\circ\text{C}$ | | | 15 | μs |
| t_f | Fall time | $V_{DM} \leq V_{DRM}$, $di_{GQ}/dt = 30 \text{ A}/\mu\text{s}$, $I_{TGQ} = I_{TGQM}$, $R_S = 5 \Omega$, $C_S = 3 \mu\text{F}$, $L_S = 0.3 \mu\text{H}$ | | | 2 | μs |
| E_{off} | Turn-on energy per pulse | $V_{DM} \leq V_{DRM}$, $di_{GQ}/dt = 30 \text{ A}/\mu\text{s}$, $I_{TGQ} = I_{TGQM}$, $R_S = 5 \Omega$, $C_S = 3 \mu\text{F}$, $L_S = 0.3 \mu\text{H}$ | | | 2 | J |
| I_{GQM} | Peak turn-off gate current | $V_{DM} \leq V_{DRM}$, $di_{GQ}/dt = 30 \text{ A}/\mu\text{s}$, $I_{TGQ} = I_{TGQM}$, $R_S = 5 \Omega$, $C_S = 3 \mu\text{F}$, $L_S = 0.3 \mu\text{H}$ | | | 480 | A |

Gate

| Symbols and parameters | | | Value | | | Unit |
|------------------------|---------------------------------|---|-------|-----|-----|------|
| | | | min | typ | max | |
| V_{GRM} | Repetitive peak reverse voltage | | | | 17 | V |
| I_{GRM} | Repetitive peak reverse current | $V_{GR} = V_{GRM}$ | | | 20 | mA |
| V_{GT} | Gate trigger voltage | $T_{vj} = 25 \text{ }^\circ\text{C}$, $V_D = 24 \text{ V}$, $R_A = 0.1 \Omega$ | | 1.5 | | V |
| I_{GT} | Gate trigger current | $T_{vj} = 25 \text{ }^\circ\text{C}$, $V_D = 24 \text{ V}$, $R_A = 0.1 \Omega$ | | 1.5 | | A |

Thermal

| Symbols and parameters | | | Value | Unit |
|------------------------|--|---------------------|-----------|------------------|
| T_{vj} | Junction operating temperature | | 0 ... 125 | $^\circ\text{C}$ |
| T_{stg} | Storage temperature range | | 0 ... 125 | $^\circ\text{C}$ |
| $R_{th(j-c)}$ | Thermal resistance junction to case | Double side cooled | 27 | K/kW |
| $R_{th(j-c)A}$ | | Anode side cooled | 49 | K/kW |
| $R_{th(j-c)C}$ | | Cathode side cooled | 60 | K/kW |
| $R_{th(c-h)}$ | Thermal resistance case to heatsink (Double side cooled) | Single side cooled | 16 | K/kW |
| $R_{th(c-h)}$ | | Double side cooled | 8 | K/kW |

DIMENSIONS

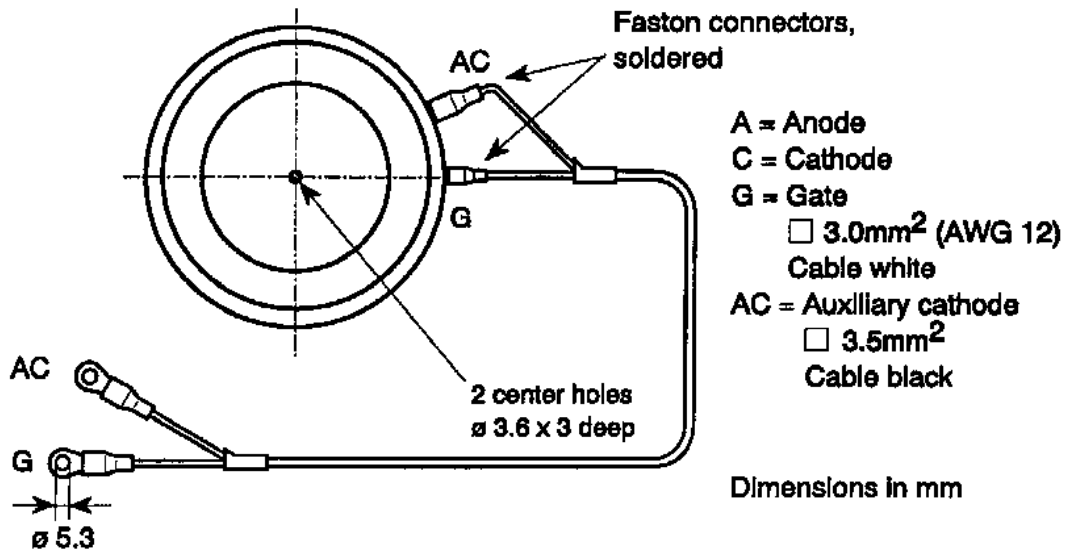
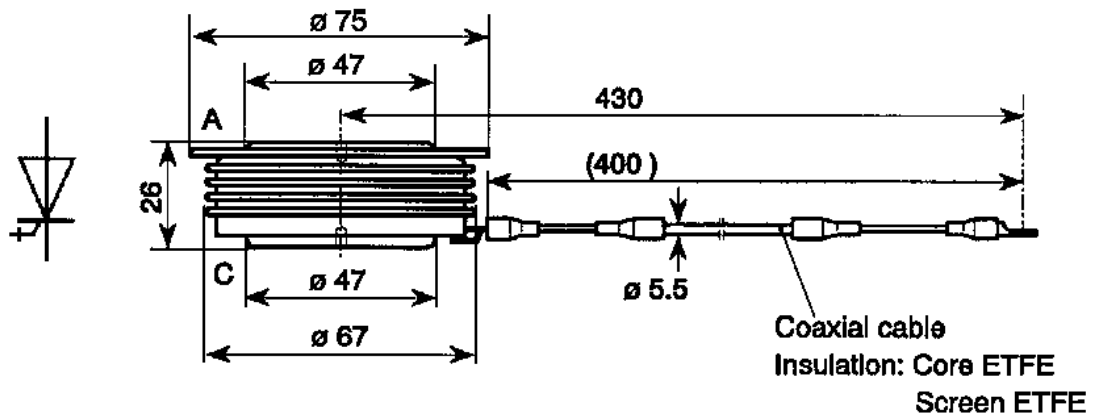

Analytical function for transient thermal impedance:

$$Z_{th(j-c)}(t) = \sum_{i=1}^n R_i(1 - e^{-t/\tau_i})$$

| i | 1 | 2 | 3 | 4 |
|-----------------------|--------|--------|--------|--------|
| R _i (K/kW) | 14.570 | 5.051 | 7.285 | 0.097 |
| τ _i (s) | 0.4610 | 0.0950 | 0.0120 | 0.0010 |

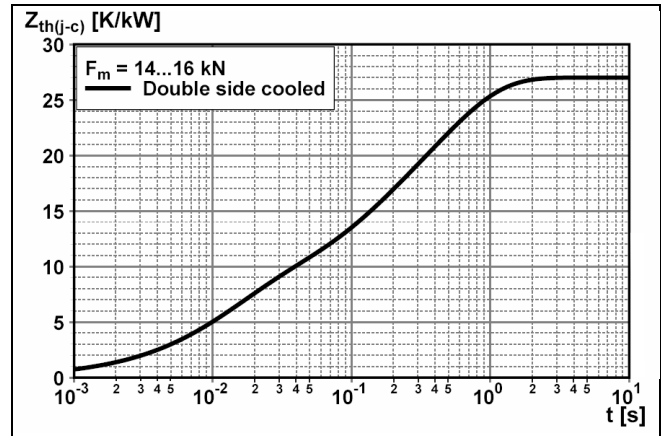

Fig. 1 Transient thermal impedance, junction to case

Max. on-state characteristic model:

$$V_{T25} = A_{T25} + B_{T25} \cdot I_T + C_{T25} \cdot \ln(I_T + 1) + D_{T25} \cdot \sqrt{I_T}$$

Valid for $i_T = 300 - 2000$ A

| A ₂₅ | B ₂₅ | C ₂₅ | D ₂₅ |
|------------------------|------------------------|------------------------|------------------------|
| 178.9×10^{-3} | 816.7×10^{-6} | 356.4×10^{-3} | -41.7×10^{-3} |

Max. on-state characteristic model:

$$V_{T125} = A_{T125} + B_{T125} \cdot I_T + C_{T125} \cdot \ln(I_T + 1) + D_{T125} \cdot \sqrt{I_T}$$

Valid for $i_T = 300 - 2000$ A

| A ₁₂₅ | B ₁₂₅ | C ₁₂₅ | D ₁₂₅ |
|-----------------------|------------------------|------------------------|------------------------|
| 11.7×10^{-3} | 630.8×10^{-6} | 340.2×10^{-3} | -22.0×10^{-3} |

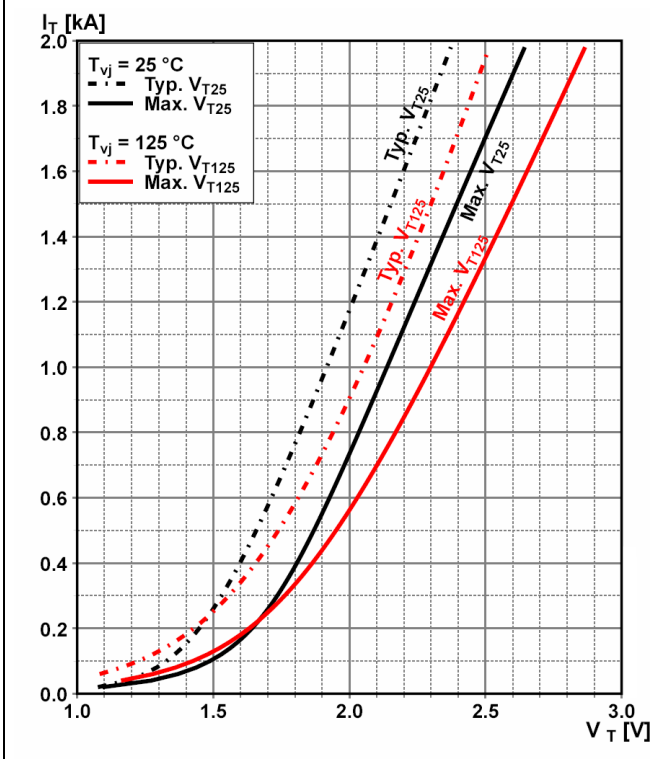

Fig. 2 On-state characteristics

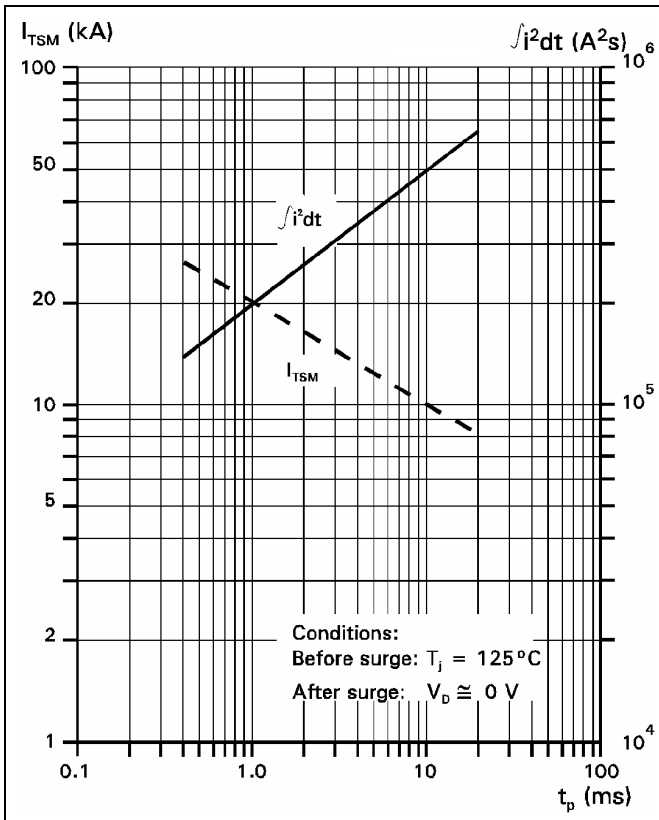

Fig. 3 Surge current and fusing integral vs. pulse width

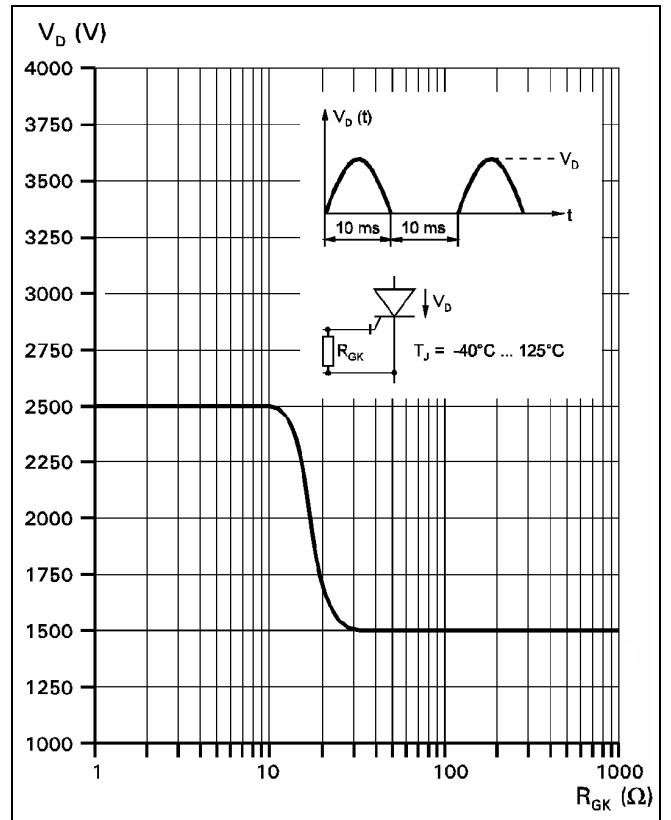

Fig. 4 Forward blocking voltage vs. gate-cathode resistance

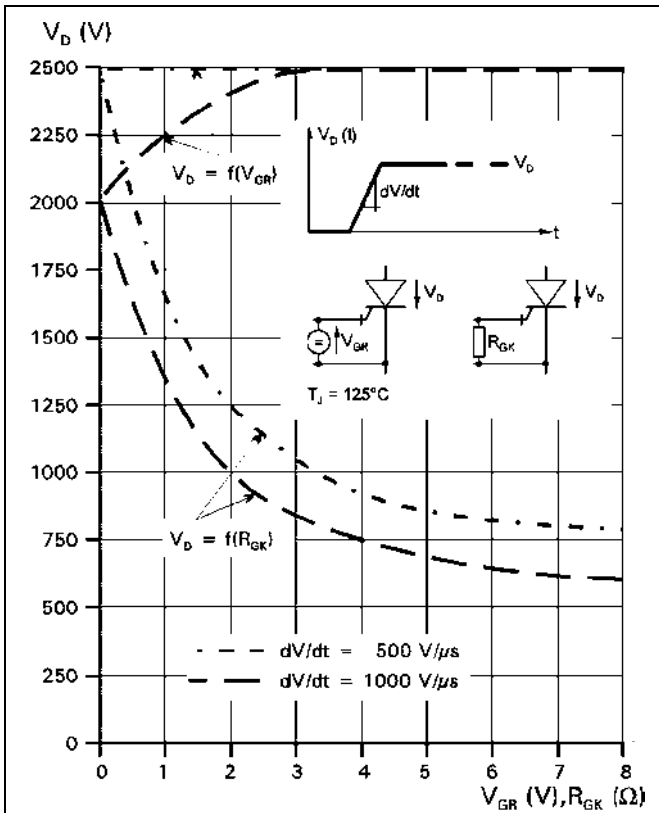

Fig. 5 Static dv/dt capability; forward blocking voltage vs. neg. gate voltage or gate cathode resistance

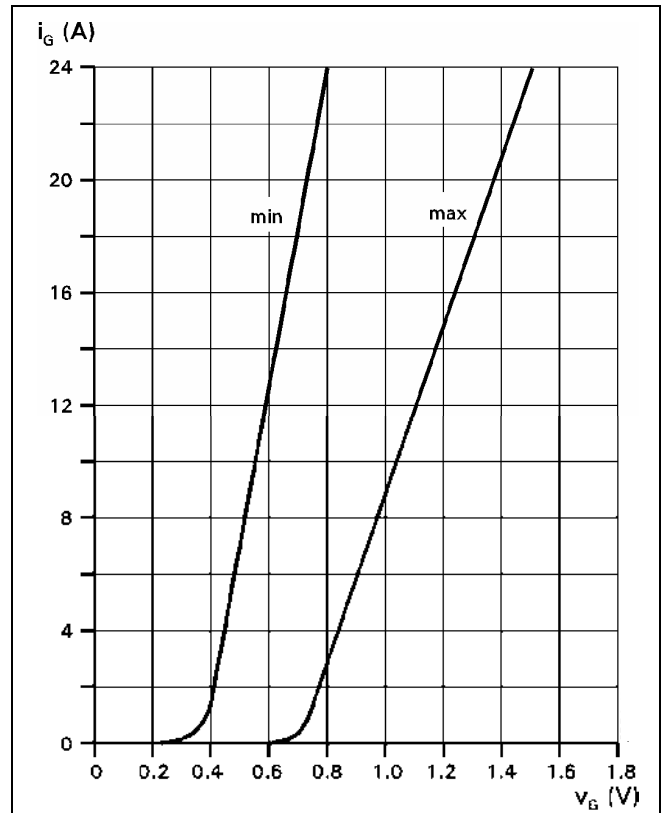

Fig. 6 Forward gate current vs. forward gate voltage

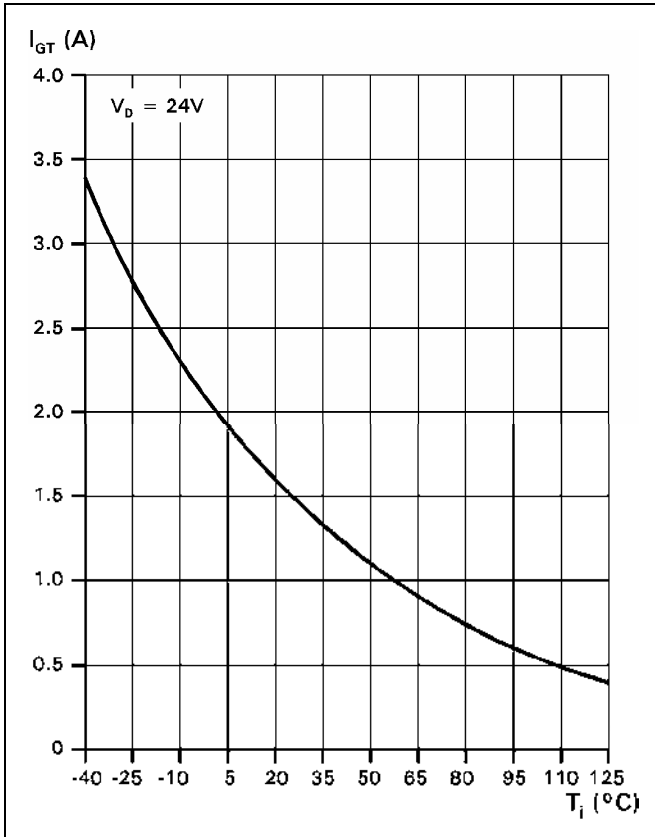

Fig. 7 Gate trigger current vs. junction temperature

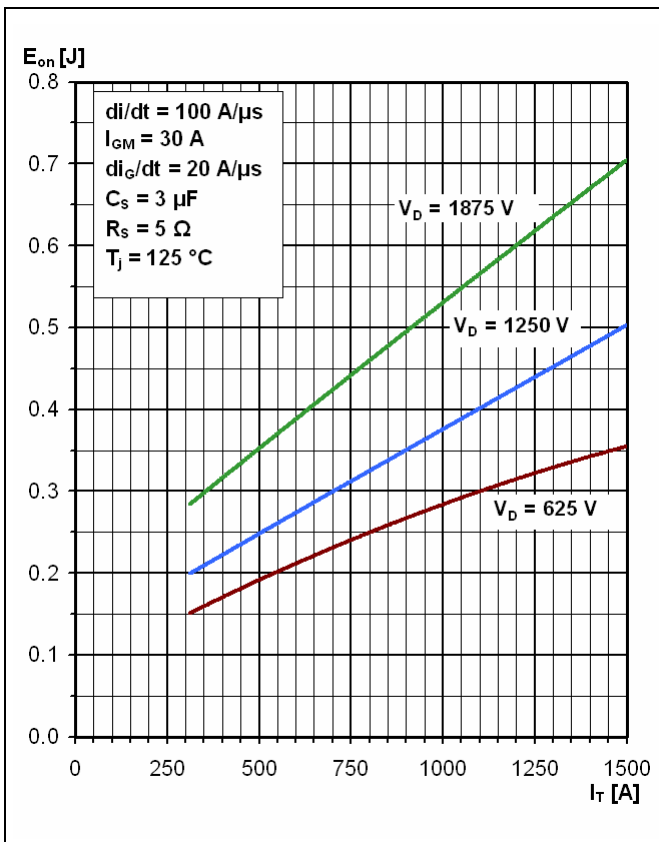

Fig. 8 Turn-on energy per pulse vs. on-state current and turn-on voltage

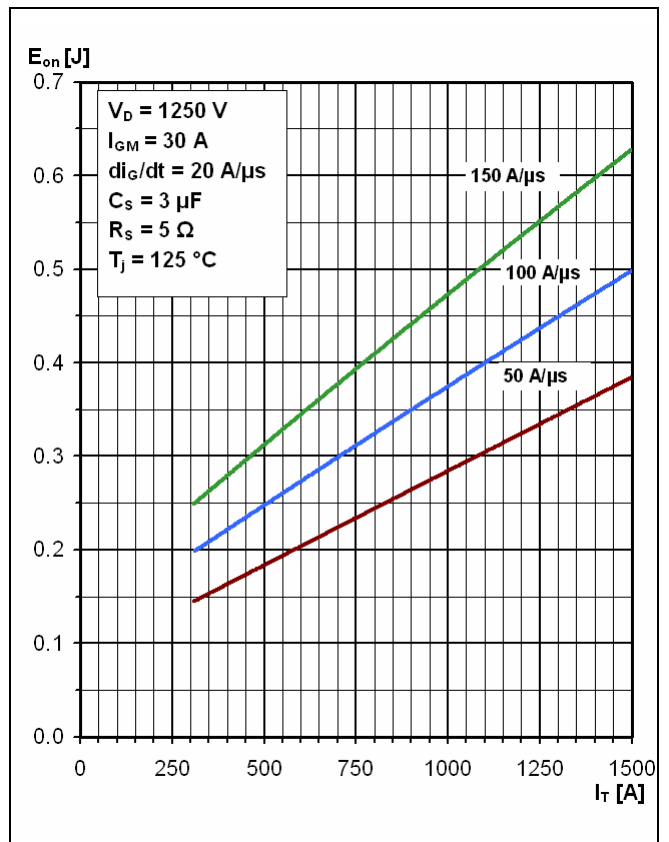

Fig. 9 Turn-on energy per pulse vs. on-state current and current rise rate

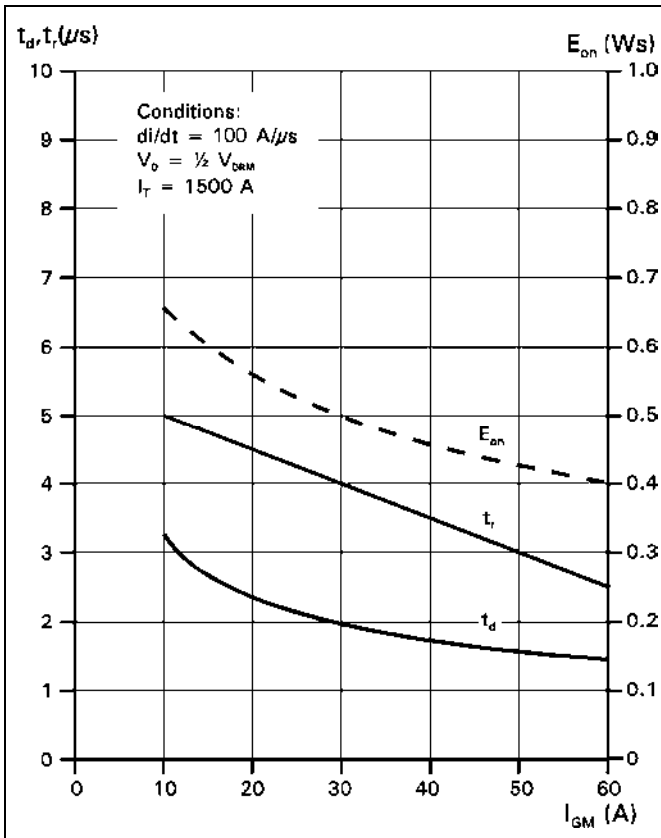

Fig. 10 Turn-on energy per pulse vs. on-state current and turn-on voltage

Common Test conditions:

- $di_G/dt = 20 \text{ A}/\mu\text{s}$
- $C_s = 3 \mu\text{F}$
- $R_s = 5 \Omega$
- $T_j = 125^\circ\text{C}$

Definition of Turn-on energy:

$$E_{on} = \int_0^{20 \text{ ms}} V_D \times I_T dt \quad (t=0, I_G = 0.1 \times I_{GM})$$

Definition of Turn-off energy:

$$E_{off} = \int_0^{40 \text{ ms}} V_D \times I_T dt \quad (t=0, I_r = 0.9 \times I_{TGO})$$

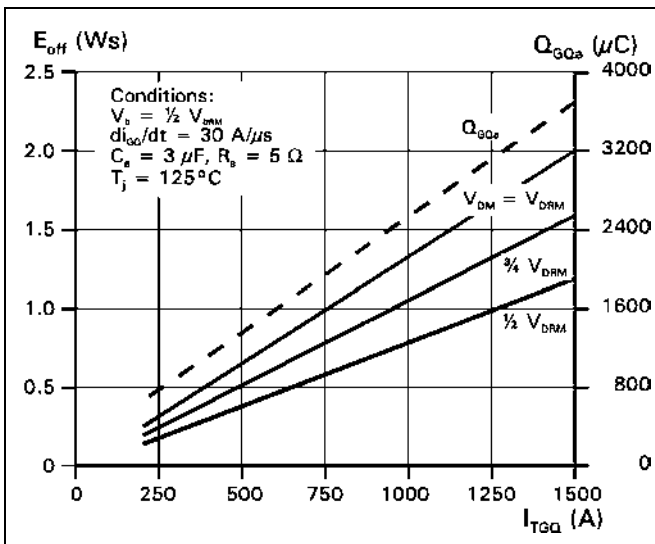

Fig. 11 Turn-off energy per pulse vs. turn-off current and peak turn-off voltage, extracted gate charge vs. turn-off current

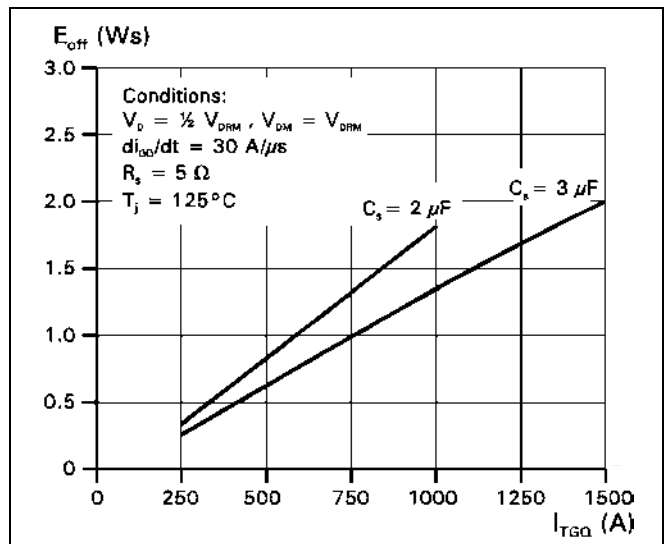

Fig. 12 Turn-off energy per pulse vs. turn-off current and snubber capacitance

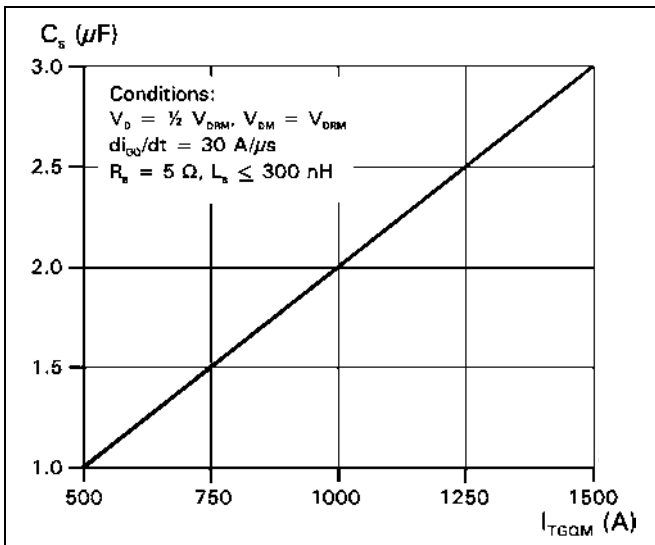

Fig. 13 Required snubber capacitor vs. max allowable turn-off current

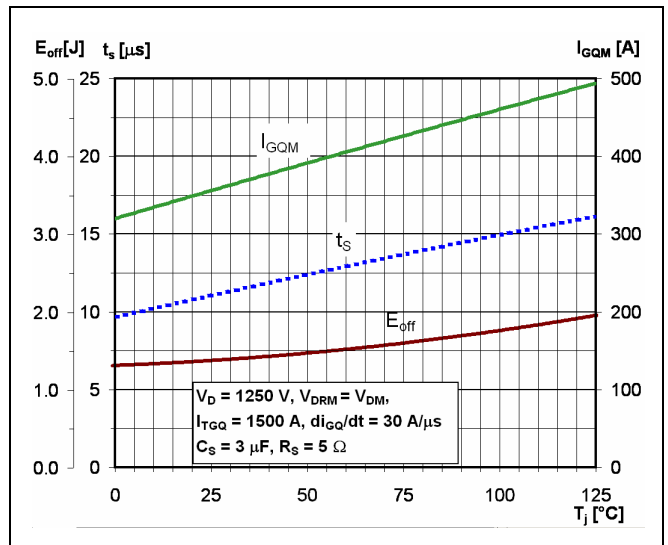

Fig. 14 Turn-off energy per pulse, storage time and peak turn-off gate current vs. junction temperature

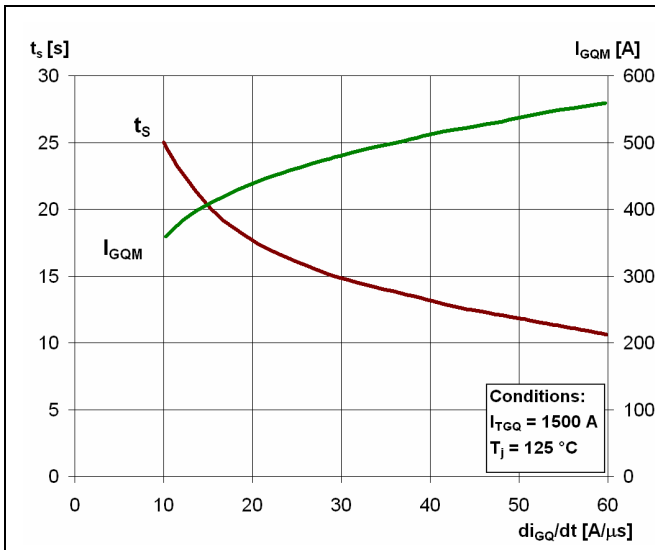

Fig. 15 Storage time and peak turn-off gate current vs. neg. gate current rise rate

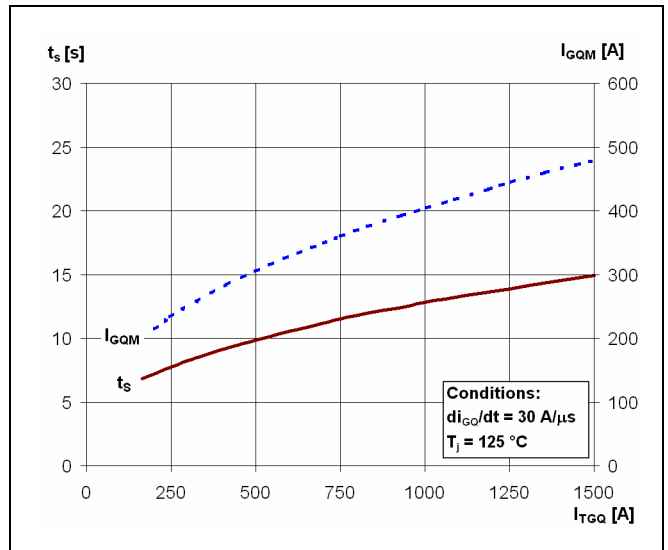

Fig. 16 Storage time and peak turn-off gate current vs. neg. gate current rise rate

