



### Key Parameters

$I_{T(AV)}$	=	70	A
$V_{DRM}/V_{RRM}$	=	1900 - 2500	V
$I_{TSM}$	=	1.7	$A \times 10^3$
$I^2t$	=	14.5	$A^2s \times 10^3$

### Features

- Isolated mounting base 3000V~
- Pressure contact technology with increased power cycling capability
- Space and weight savings

### Applications

- AC/DC Motor drives
- Various rectifiers
- DC supply for PWM inverter

SYMBOL	CHARACTERISTIC	TEST CONDITIONS	$T_j(^{\circ}C)$	VALUE			UNIT
				Min	Type	Max	
$I_{T(AV)}$	Mean on-state current	180° half sine wave 50Hz Single side cooled, $T_c=85^{\circ}C$	125			70	A
$I_{T(RMS)}$	RMS on-state current		125			110	A
$V_{DRM}$ $V_{RRM}$	Repetitive peak off-state voltage Repetitive peak reverse voltage	$V_{DRM} \& V_{RRM} t_p=10ms$ $V_{DSM} \& V_{RSM} = V_{DRM} \& V_{RRM} + 100V$ respectively	125	1900		2500	V
$I_{DRM}$ $I_{RRM}$	Repetitive peak current	at $V_{DRM}$ at $V_{RRM}$	125			12	mA
$I_{TSM}$	Surge on-state current	10ms half sine wave	125			1.70	KA
$I^2t$	$I^2T$ for fusing coordination	$V_R=60\%V_{RRM}$				14.5	$A^2s \times 10^3$
$V_{TO}$	Threshold voltage		125			0.85	V
$r_T$	On-state slop resistance					3.50	mΩ
$V_{TM}$	Peak on-state voltage	$I_{TM}=210A$	25			1.93	V
$dv/dt$	Critical rate of rise of off-state voltage	$V_{DM}=67\%V_{DRM}$	125			800	V/μs
$di/dt$	Critical rate of rise of on-state current	$I_{TM}=140A$ , Gate source 1.5A $t_r \leq 0.5\mu s$ Repetitive	125			50	A/μs
$I_{GT}$	Gate trigger current			30		100	mA
$V_{GT}$	Gate trigger voltage	$V_A=12V, I_A=1A$	25	0.8		2.5	V
$I_H$	Holding current			20		150	mA
$V_{GD}$	Non-trigger gate voltage	$V_{DM}=67\%V_{DRM}$	125	0.2			V
$R_{th(j-c)}$	Thermal resistance Junction to case	Single side cooled				0.39	$^{\circ}C/W$
$R_{th(c-h)}$	Thermal resistance case to heat sink	Single side cooled				0.2	$^{\circ}C/W$
$V_{iso}$	Isolation voltage	50Hz, R.M.S, $t=1min, I_{iso}:1mA(MAX)$		3000			V
$F_m$	Thermal connection torque (M5)				4.0		N-m
	Mounting torque (M6)				6.0		N-m
$T_{stg}$	Stored temperature			-40		125	$^{\circ}C$
$W_t$	Weight				115		g
Outline							

## DIMENSIONES

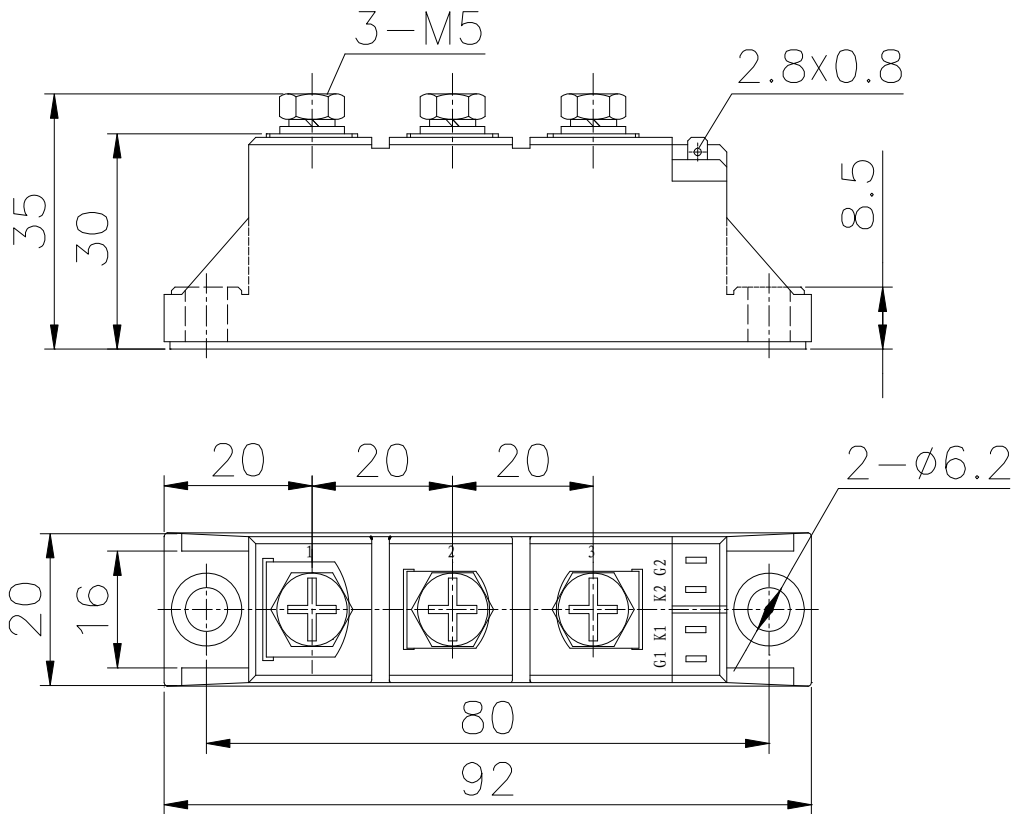

All dimensions in millimeters

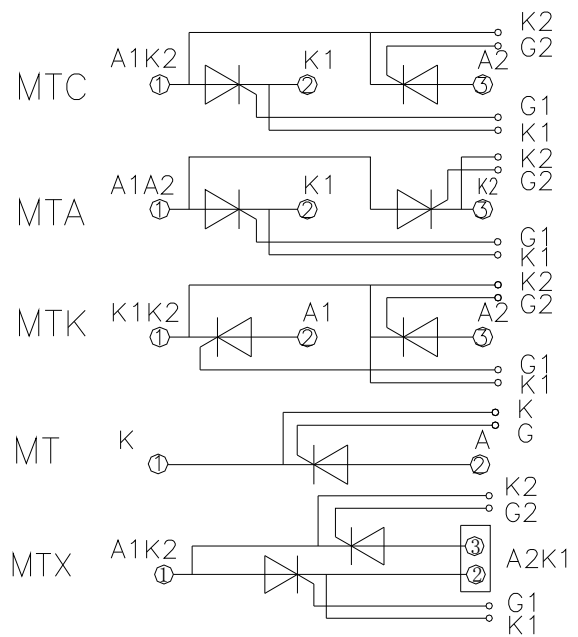

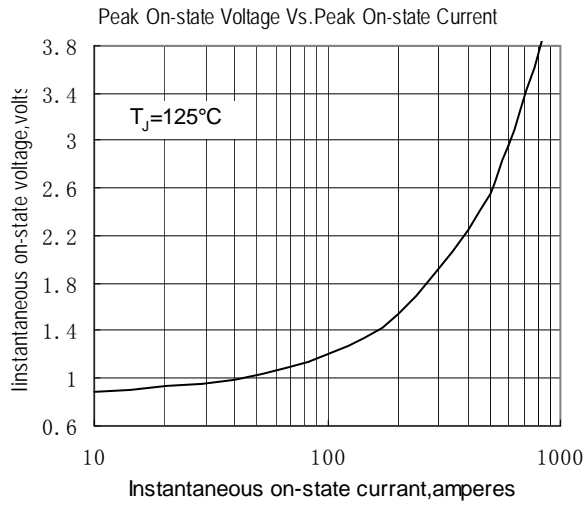

Fig. 1

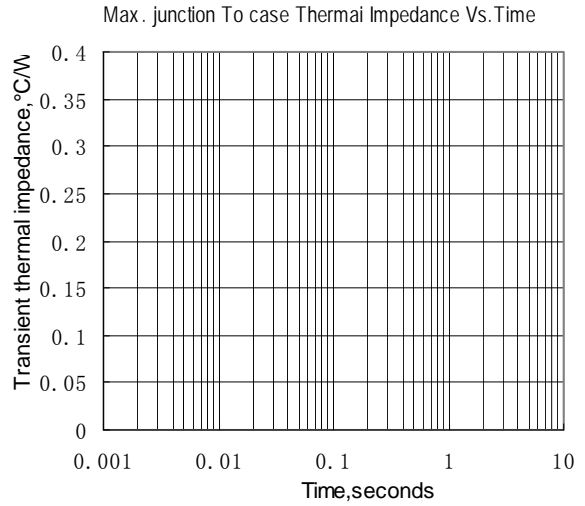

Fig. 2

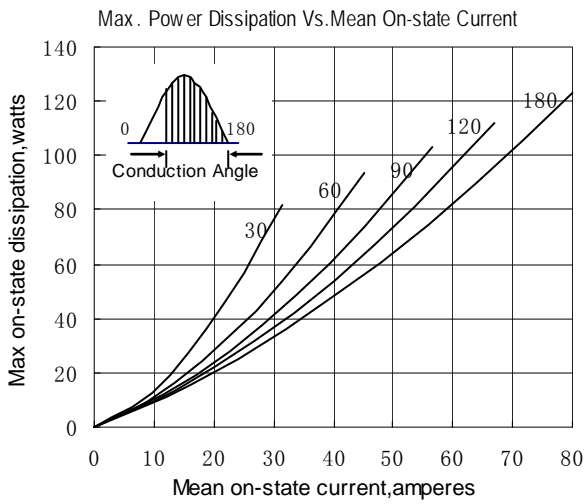

Fig. 3

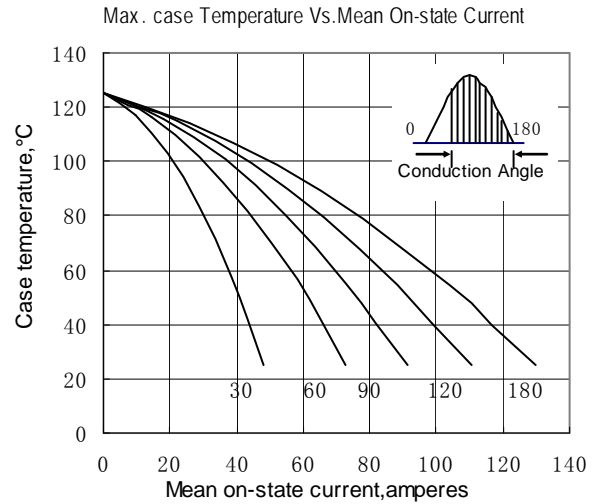

Fig. 4

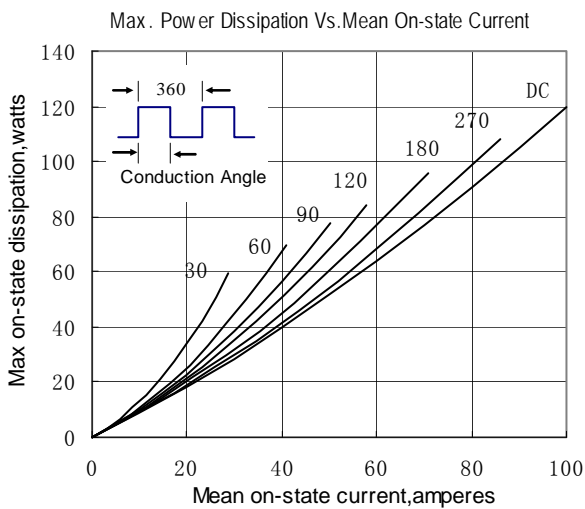

Fig. 5

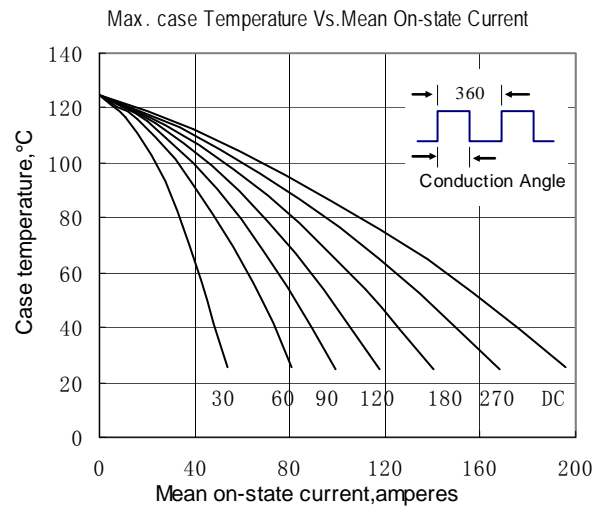

Fig. 6

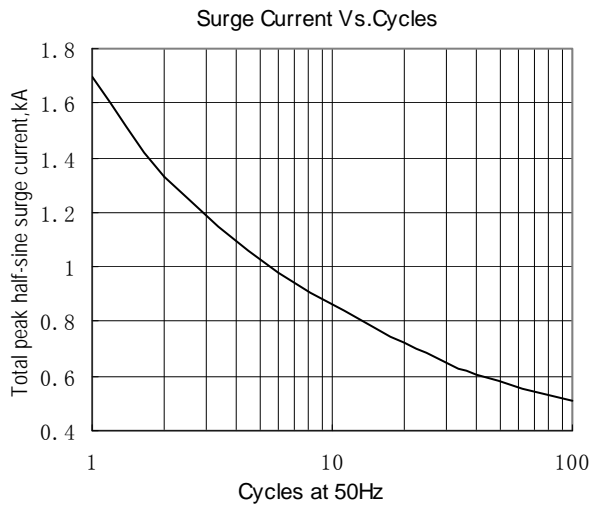

Fig.7

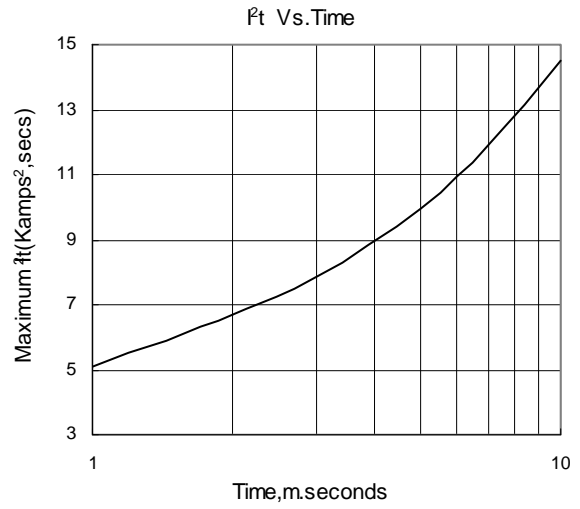

Fig.8

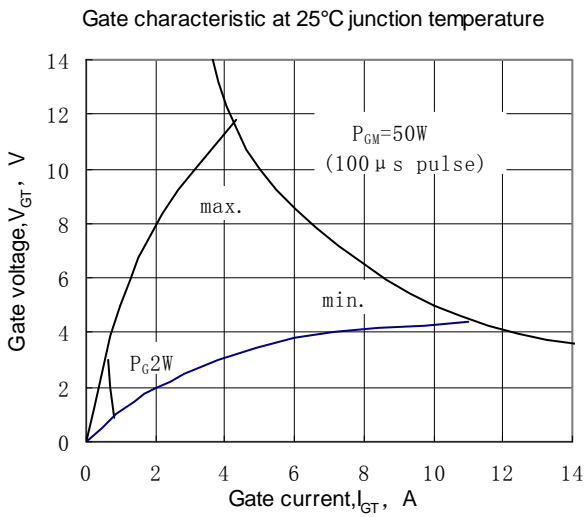

Fig.9

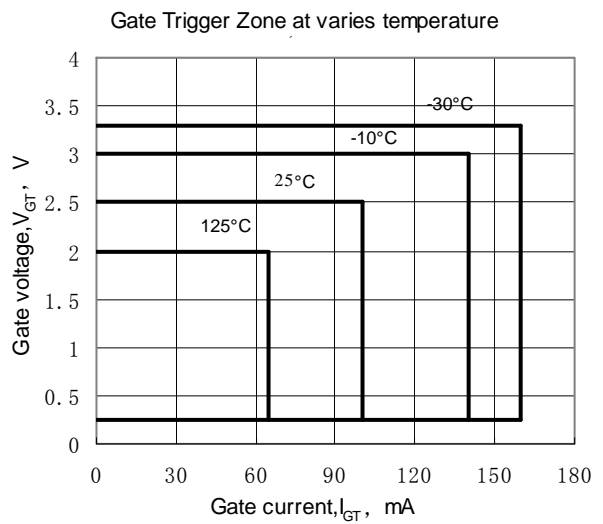

Fig.10