

## IHM-B module with Trench/Fieldstop IGBT4 and emitter controlled 4 diode

### Features

- Electrical features
  - $V_{CES} = 3300\text{ V}$
  - $I_{C\text{ nom}} = 825\text{ A} / I_{CRM} = 1650\text{ A}$
  - Low  $Q_g$  and  $C_{res}$
  - High DC stability
  - High short-circuit capability
  - Low switching losses
  - Low  $V_{CE,sat}$
  - $T_{vj,op} = 150^\circ\text{C}$
  - Trench IGBT 4
  - Unbeatable robustness
  - $V_{CE,sat}$  with positive temperature coefficient
  - High current density
- Mechanical features
  - ALSiC base plate for increased thermal cycling capability
  - High power density
  - Isolated base plate
  - Package with CTI > 600
  - RoHS compliant



### Potential applications

- High-power converters
- Medium-voltage converters
- Motor drives
- Traction drives
- UPS systems
- Active frontend (energy recovery)

### Product validation

- Qualified for industrial applications according to the relevant tests of IEC 60747, 60749 and 60068

### Description

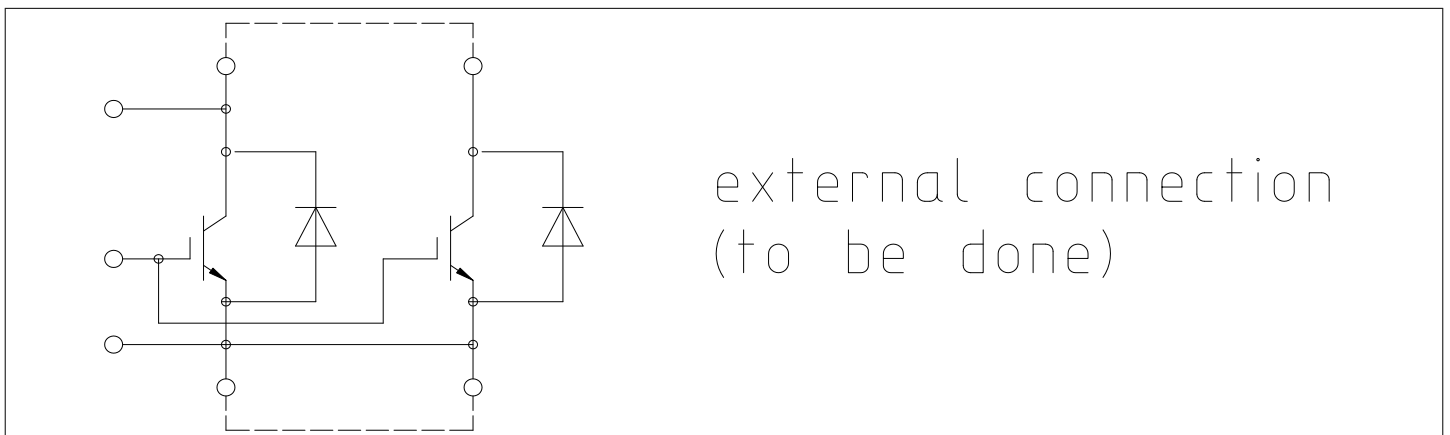

**Table of contents**

	<b>Description</b> .....	1
	<b>Features</b> .....	1
	<b>Potential applications</b> .....	1
	<b>Product validation</b> .....	1
	<b>Table of contents</b> .....	2
<b>1</b>	<b>Package</b> .....	3
<b>2</b>	<b>IGBT, Inverter</b> .....	3
<b>3</b>	<b>Diode, Inverter</b> .....	5
<b>4</b>	<b>Characteristics diagrams</b> .....	7
<b>5</b>	<b>Circuit diagram</b> .....	11
<b>6</b>	<b>Package outlines</b> .....	11
<b>7</b>	<b>Module label code</b> .....	12
	<b>Revision history</b> .....	13
	<b>Disclaimer</b> .....	14

## 1 Package

**Table 1 Insulation coordination**

Parameter	Symbol	Note or test condition	Values	Unit
Isolation test voltage	$V_{ISOL}$	RMS, $f = 50$ Hz	6.0	kV
Partial discharge extinction voltage	$V_{isol}$	RMS, $f = 50$ Hz, $Q_{PD} \leq 10$ pC	2.6	kV
DC stability	$V_{CE(D)}$	$T_{vj} = 25$ °C, 100 Fit	2100	V
Material of module baseplate			AlSiC	
Creepage distance	$d_{Creep}$	terminal to heatsink	32.2	mm
Clearance	$d_{Clear}$	terminal to heatsink	19.1	mm
Comparative tracking index	$CTI$		> 600	

**Table 2 Characteristic values**

Parameter	Symbol	Note or test condition	Values			Unit	
			Min.	Typ.	Max.		
Stray inductance module	$L_{sCE}$			9		nH	
Module lead resistance, terminals - chip	$R_{AA'+CC'}$	$T_C = 25$ °C, per switch		0.12		mΩ	
Module lead resistance, terminals - chip	$R_{CC'+EE'}$	$T_C = 25$ °C, per switch		0.2		mΩ	
Storage temperature	$T_{stg}$		-40		150	°C	
Mounting torque for module mounting	$M$	- Mounting according to valid application note	M6, Screw	4.25		5.75	Nm
Terminal connection torque	$M$	- Mounting according to valid application note	M4, Screw	1.8		2.1	Nm
			M8, Screw	8		10	
Weight	$G$			800		g	

## 2 IGBT, Inverter

**Table 3 Maximum rated values**

Parameter	Symbol	Note or test condition	Values	Unit	
Collector-emitter voltage	$V_{CES}$		$T_{vj} = -40$ °C	3300	V
			$T_{vj} = 150$ °C	3300	
Continuous DC collector current	$I_{CDC}$	$T_{vj\ max} = 150$ °C	$T_C = 105$ °C	825	A
Repetitive peak collector current	$I_{CRM}$	$t_p$ limited by $T_{vj\ op}$		1650	A

(table continues...)

**Table 3 (continued) Maximum rated values**

Parameter	Symbol	Note or test condition	Values	Unit
Gate-emitter peak voltage	$V_{GES}$		$\pm 20$	V

**Table 4 Characteristic values**

Parameter	Symbol	Note or test condition	Values			Unit
			Min.	Typ.	Max.	
Collector-emitter saturation voltage	$V_{CE\ sat}$	$I_C = 825\ A, V_{GE} = 15\ V$	$T_{vj} = 25\ ^\circ C$	2.40	2.65	V
			$T_{vj} = 125\ ^\circ C$	3.00		
			$T_{vj} = 150\ ^\circ C$	3.13	3.28	
Gate threshold voltage	$V_{GEth}$	$I_C = 32\ mA, V_{CE} = V_{GE}, T_{vj} = 25\ ^\circ C$	5.20	5.80	6.40	V
Gate charge	$Q_G$	$V_{GE} = \pm 15\ V, V_{CC} = 1800\ V$		14		$\mu C$
Internal gate resistor	$R_{Gint}$	$T_{vj} = 25\ ^\circ C$		1.5		$\Omega$
Input capacitance	$C_{ies}$	$f = 1000\ kHz, T_{vj} = 25\ ^\circ C, V_{CE} = 25\ V, V_{GE} = 0\ V$		93.5		nF
Reverse transfer capacitance	$C_{res}$	$f = 1000\ kHz, T_{vj} = 25\ ^\circ C, V_{CE} = 25\ V, V_{GE} = 0\ V$		2.67		nF
Collector-emitter cut-off current	$I_{CES}$	$V_{CE} = 3300\ V, V_{GE} = 0\ V$	$T_{vj} = 25\ ^\circ C$		5	mA
Gate-emitter leakage current	$I_{GES}$	$V_{CE} = 0\ V, V_{GE} = 20\ V, T_{vj} = 25\ ^\circ C$			400	nA
Turn-on delay time (inductive load)	$t_{don}$	$I_C = 825\ A, V_{CC} = 1800\ V, V_{GE} = \pm 15\ V, R_{Gon} = 0.5\ \Omega$	$T_{vj} = 25\ ^\circ C$	0.560		$\mu s$
			$T_{vj} = 125\ ^\circ C$	0.605		
			$T_{vj} = 150\ ^\circ C$	0.615		
Rise time (inductive load)	$t_r$	$I_C = 825\ A, V_{CC} = 1800\ V, V_{GE} = \pm 15\ V, R_{Gon} = 0.5\ \Omega$	$T_{vj} = 25\ ^\circ C$	0.130		$\mu s$
			$T_{vj} = 125\ ^\circ C$	0.150		
			$T_{vj} = 150\ ^\circ C$	0.160		
Turn-off delay time (inductive load)	$t_{doff}$	$I_C = 825\ A, V_{CC} = 1800\ V, V_{GE} = \pm 15\ V, R_{Goff} = 7\ \Omega$	$T_{vj} = 25\ ^\circ C$	3.200		$\mu s$
			$T_{vj} = 125\ ^\circ C$	3.450		
			$T_{vj} = 150\ ^\circ C$	3.500		
Fall time (inductive load)	$t_f$	$I_C = 825\ A, V_{CC} = 1800\ V, V_{GE} = \pm 15\ V, R_{Goff} = 7\ \Omega$	$T_{vj} = 25\ ^\circ C$	0.900		$\mu s$
			$T_{vj} = 125\ ^\circ C$	1.450		
			$T_{vj} = 150\ ^\circ C$	1.650		
Turn-on time (resistive load)	$t_{on\_R}$	$I_C = 500\ A, V_{CC} = 2000\ V, V_{GE} = \pm 15\ V, R_{Gon} = 0.5\ \Omega$	$T_{vj} = 25\ ^\circ C$	1.09		$\mu s$
Turn-on energy loss per pulse	$E_{on}$	$I_C = 825\ A, V_{CC} = 1800\ V, L_\sigma = 85\ nH, V_{GE} = \pm 15\ V, R_{Gon} = 0.5\ \Omega, di/dt = 4700\ A/\mu s (T_{vj} = 150\ ^\circ C)$	$T_{vj} = 25\ ^\circ C$	920		mJ
			$T_{vj} = 125\ ^\circ C$	1450		
			$T_{vj} = 150\ ^\circ C$	1630		

(table continues...)

**Table 4 (continued) Characteristic values**

Parameter	Symbol	Note or test condition	Values			Unit
			Min.	Typ.	Max.	
Turn-off energy loss per pulse	$E_{off}$	$I_C = 825\text{ A}, V_{CC} = 1800\text{ V}, L_\sigma = 85\text{ nH}, V_{GE} = \pm 15\text{ V}, R_{Goff} = 7\ \Omega, dv/dt = 1700\text{ V}/\mu\text{s} (T_{vj} = 150\text{ }^\circ\text{C})$	$T_{vj} = 25\text{ }^\circ\text{C}$	1100		mJ
			$T_{vj} = 125\text{ }^\circ\text{C}$	1470		
			$T_{vj} = 150\text{ }^\circ\text{C}$	1580		
SC data	$I_{SC}$	$V_{GE} \leq 15\text{ V}, V_{CC} = 2400\text{ V}, V_{CEmax} = V_{CES} - L_{sCE} * di/dt$	$t_p \leq 10\ \mu\text{s}, T_{vj} \leq 150\text{ }^\circ\text{C}$	3600		A
Thermal resistance, junction to case	$R_{thJC}$	per IGBT			18.0	K/kW
Thermal resistance, case to heat sink	$R_{thCH}$	per IGBT		7.17		K/kW
Temperature under switching conditions	$T_{vjop}$		-40		150	$^\circ\text{C}$

### 3 Diode, Inverter

**Table 5 Maximum rated values**

Parameter	Symbol	Note or test condition	Values	Unit	
Repetitive peak reverse voltage	$V_{RRM}$		$T_{vj} = -40\text{ }^\circ\text{C}$	3300	V
			$T_{vj} = 150\text{ }^\circ\text{C}$	3300	
Continuous DC forward current	$I_F$		825	A	
Repetitive peak forward current	$I_{FRM}$	$t_p = 1\text{ ms}$	1650	A	
$I^2t$ - value	$I^2t$	$t_p = 10\text{ ms}, V_R = 0\text{ V}$	$T_{vj} = 125\text{ }^\circ\text{C}$	280	kA <sup>2</sup> s
			$T_{vj} = 150\text{ }^\circ\text{C}$	253	
Maximum power dissipation	$P_{RQM}$		$T_{vj} = 150\text{ }^\circ\text{C}$	2400	kW
Minimum turn-on time	$t_{onmin}$			10	$\mu\text{s}$

**Table 6 Characteristic values**

Parameter	Symbol	Note or test condition	Values			Unit	
			Min.	Typ.	Max.		
Forward voltage	$V_F$	$I_F = 825\text{ A}, V_{GE} = 0\text{ V}$	$T_{vj} = 25\text{ }^\circ\text{C}$		2.55	2.95	V
			$T_{vj} = 125\text{ }^\circ\text{C}$		2.30		
			$T_{vj} = 150\text{ }^\circ\text{C}$		2.20	2.50	

(table continues...)

**Table 6 (continued) Characteristic values**

Parameter	Symbol	Note or test condition	Values			Unit
			Min.	Typ.	Max.	
Peak reverse recovery current	$I_{RM}$	$V_{CC} = 1800\text{ V}$ , $I_F = 825\text{ A}$ , $V_{GE} = -15\text{ V}$ , $-di_F/dt = 4700\text{ A}/\mu\text{s}$ ( $T_{vj} = 150\text{ }^\circ\text{C}$ )	$T_{vj} = 25\text{ }^\circ\text{C}$		1180	A
			$T_{vj} = 125\text{ }^\circ\text{C}$		1240	
			$T_{vj} = 150\text{ }^\circ\text{C}$		1250	
Recovered charge	$Q_r$	$V_{CC} = 1800\text{ V}$ , $I_F = 825\text{ A}$ , $V_{GE} = -15\text{ V}$ , $-di_F/dt = 4700\text{ A}/\mu\text{s}$ ( $T_{vj} = 150\text{ }^\circ\text{C}$ )	$T_{vj} = 25\text{ }^\circ\text{C}$		430	$\mu\text{C}$
			$T_{vj} = 125\text{ }^\circ\text{C}$		830	
			$T_{vj} = 150\text{ }^\circ\text{C}$		970	
Reverse recovery energy	$E_{rec}$	$V_{CC} = 1800\text{ V}$ , $I_F = 825\text{ A}$ , $V_{GE} = -15\text{ V}$ , $-di_F/dt = 4700\text{ A}/\mu\text{s}$ ( $T_{vj} = 150\text{ }^\circ\text{C}$ )	$T_{vj} = 25\text{ }^\circ\text{C}$		390	mJ
			$T_{vj} = 125\text{ }^\circ\text{C}$		875	
			$T_{vj} = 150\text{ }^\circ\text{C}$		1050	
Thermal resistance, junction to case	$R_{thJC}$	per diode			25.2	K/kW
Thermal resistance, case to heat sink	$R_{thCH}$	per diode		9.43		K/kW
Temperature under switching conditions	$T_{vj\text{ op}}$		-40		150	$^\circ\text{C}$

## 4 Characteristics diagrams

### Output characteristic (typical), IGBT, Inverter

$$I_C = f(V_{CE})$$

$$V_{GE} = 15 \text{ V}$$

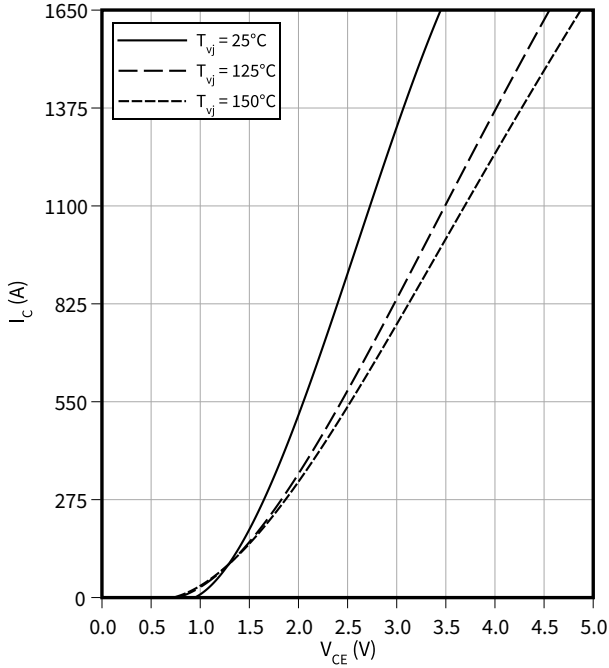

### Output characteristic field (typical), IGBT, Inverter

$$I_C = f(V_{CE})$$

$$T_{vj} = 150 \text{ °C}$$

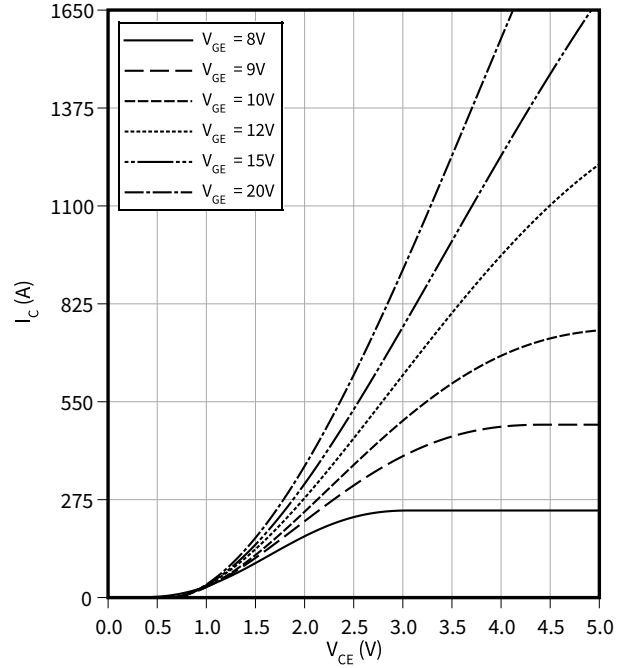

### Transfer characteristic (typical), IGBT, Inverter

$$I_C = f(V_{GE})$$

$$V_{CE} = 20 \text{ V}$$

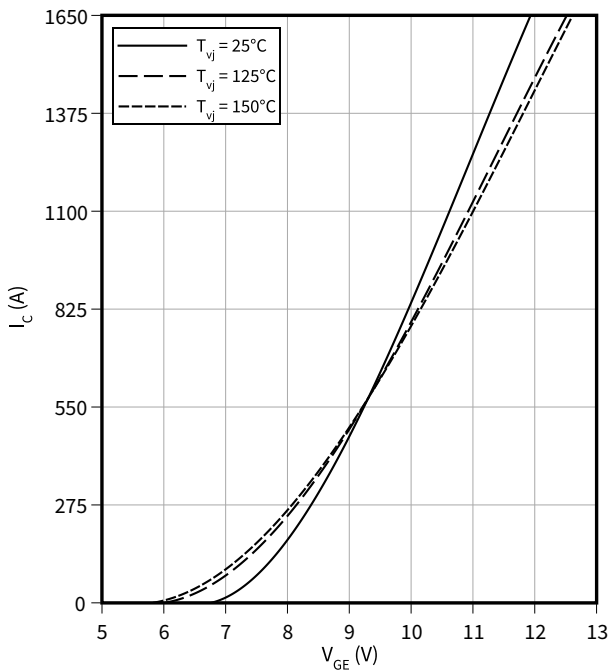

### Switching losses (typical), IGBT, Inverter

$$E = f(I_C)$$

$$R_{Goff} = 7 \text{ } \Omega, R_{Gon} = 0.5 \text{ } \Omega, V_{CC} = 1800 \text{ V}, V_{GE} = \pm 15 \text{ V}$$

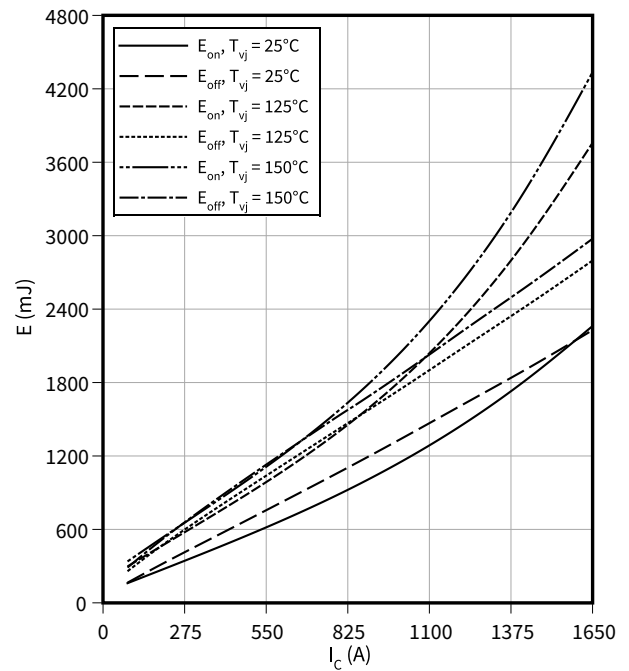

**Switching losses (typical), IGBT, Inverter**

$E = f(R_G)$

$I_C = 825 \text{ A}$ ,  $V_{CC} = 1800 \text{ V}$ ,  $V_{GE} = \pm 15 \text{ V}$

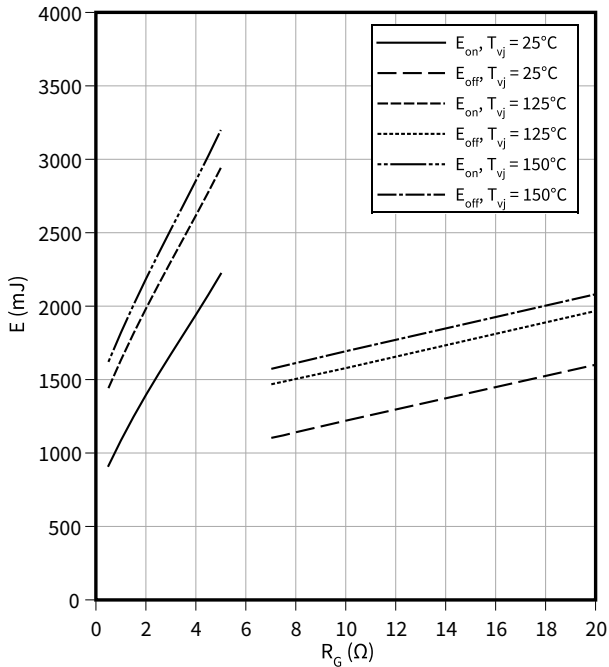

**Switching times (typical), IGBT, Inverter**

$t = f(I_C)$

$R_{Goff} = 7 \Omega$ ,  $R_{Gon} = 0.5 \Omega$ ,  $V_{CC} = 1800 \text{ V}$ ,  $V_{GE} = \pm 15 \text{ V}$ ,  $T_{vj} = 150 \text{ }^\circ\text{C}$

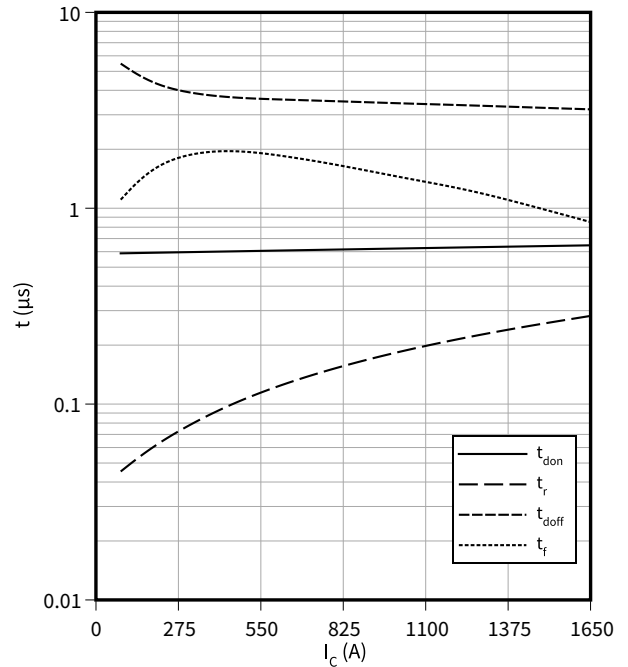

**Switching times (typical), IGBT, Inverter**

$t = f(R_G)$

$I_C = 825 \text{ A}$ ,  $V_{CC} = 1800 \text{ V}$ ,  $V_{GE} = \pm 15 \text{ V}$ ,  $T_{vj} = 150 \text{ }^\circ\text{C}$

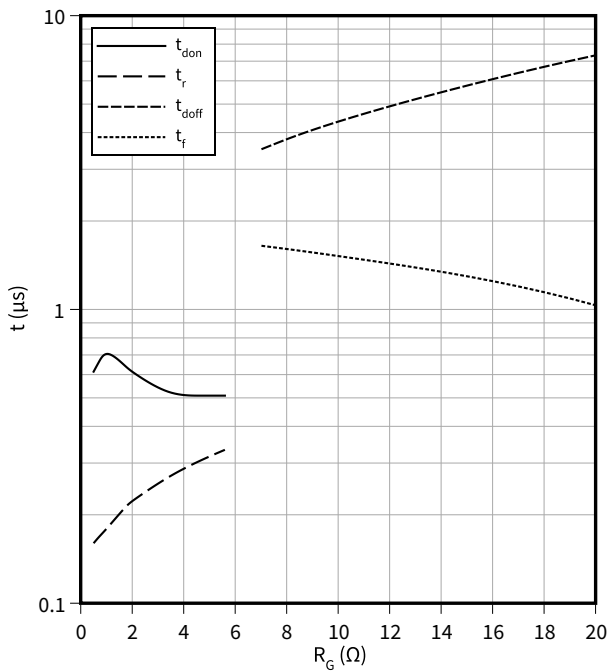

**Transient thermal impedance, IGBT, Inverter**

$Z_{th} = f(t)$

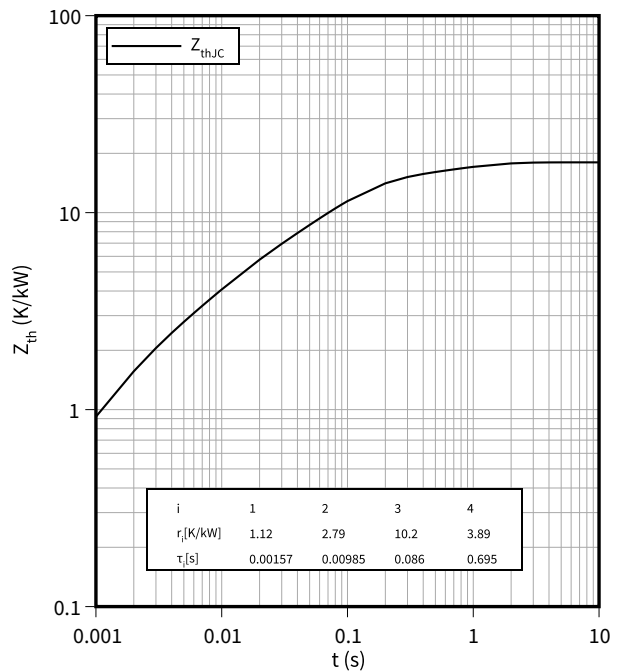



4 Characteristics diagrams

**Reverse bias safe operating area (RBSOA), IGBT, Inverter**

$I_C = f(V_{CE})$

$R_{Goff} = 7 \Omega$ ,  $V_{GE} = 15 \text{ V}$ ,  $T_{vj} = 150 \text{ }^\circ\text{C}$

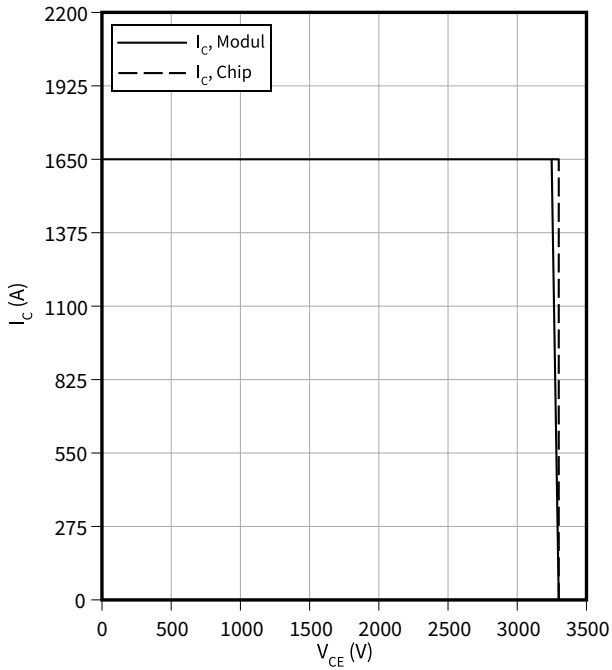

**Capacity characteristic (typical), IGBT, Inverter**

$C = f(V_{CE})$

$f = 1000 \text{ kHz}$ ,  $V_{GE} = 0 \text{ V}$ ,  $T_{vj} = 25 \text{ }^\circ\text{C}$

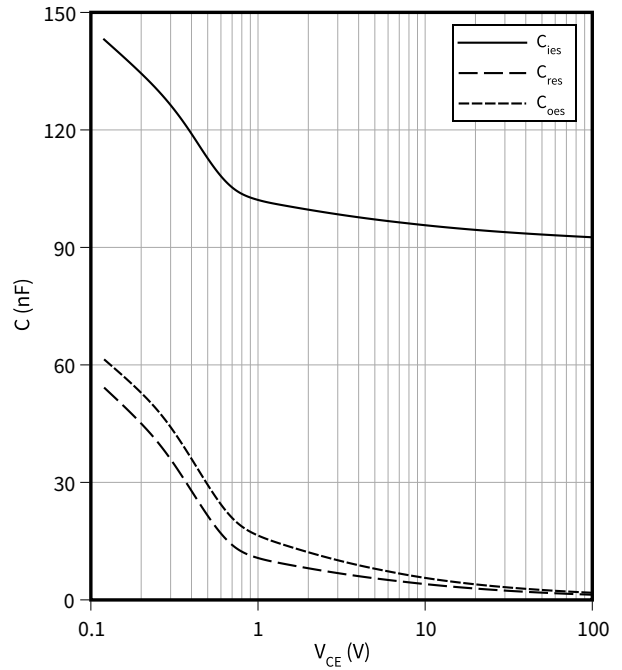

**Gate charge characteristic (typical), IGBT, Inverter**

$V_{GE} = f(Q_G)$

$I_C = 825 \text{ A}$ ,  $T_{vj} = 25 \text{ }^\circ\text{C}$

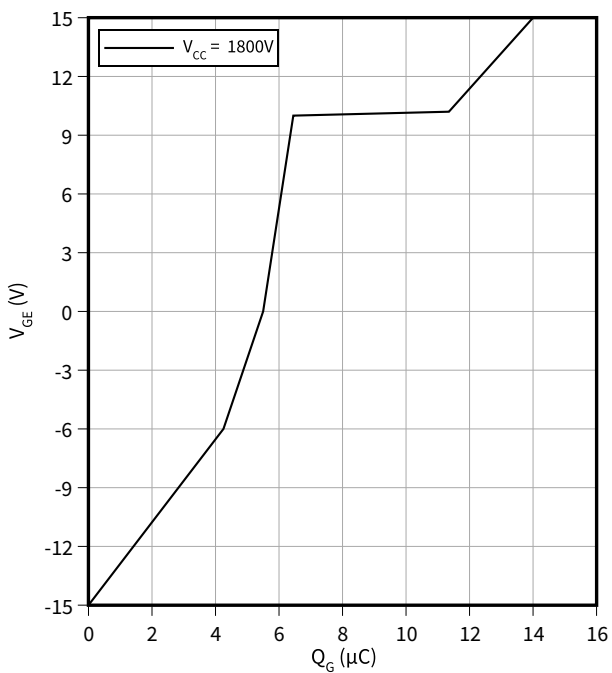

**Forward characteristic (typical), Diode, Inverter**

$I_F = f(V_F)$

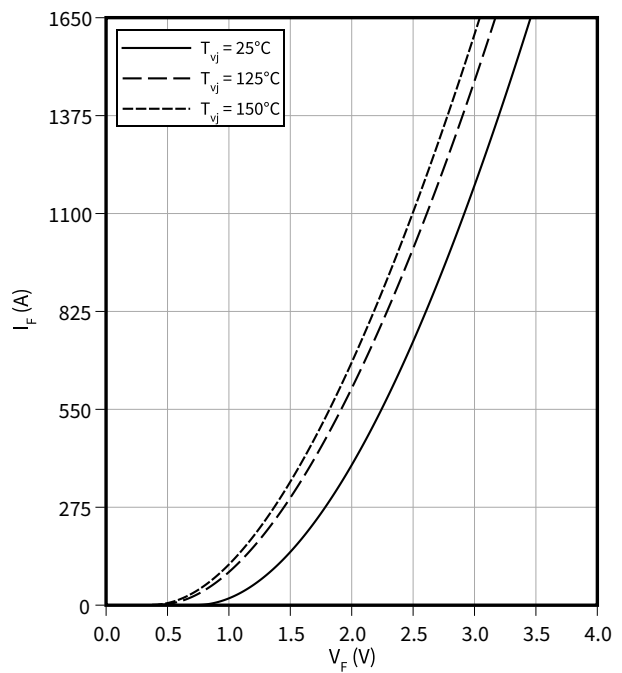

**Switching losses (typical), Diode, Inverter**

$E_{rec} = f(I_F)$

$V_{CE} = 1800\text{ V}$ ,  $R_{Gon} = R_{Gon}(IGBT)$

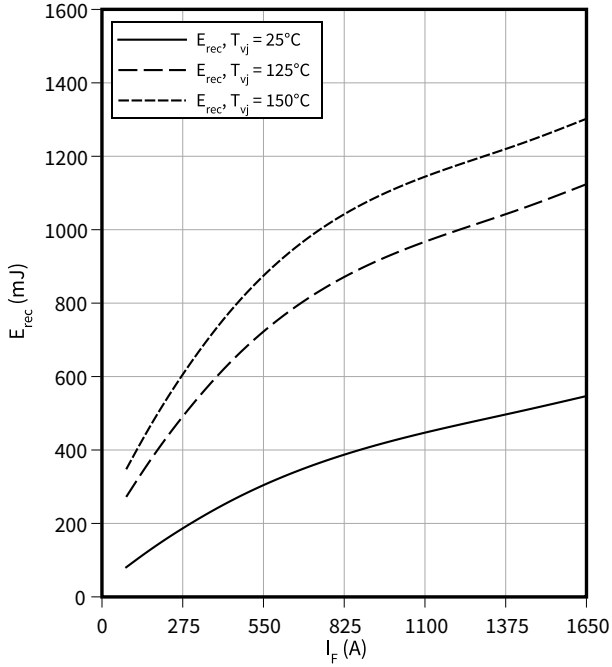

**Switching losses (typical), Diode, Inverter**

$E_{rec} = f(R_G)$

$V_{CE} = 1800\text{ V}$ ,  $I_F = 825\text{ A}$

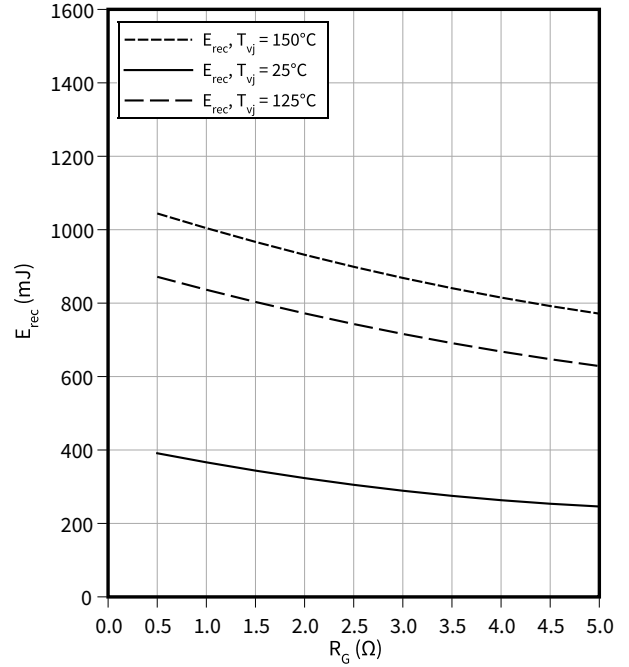

**Transient thermal impedance, Diode, Inverter**

$Z_{th} = f(t)$

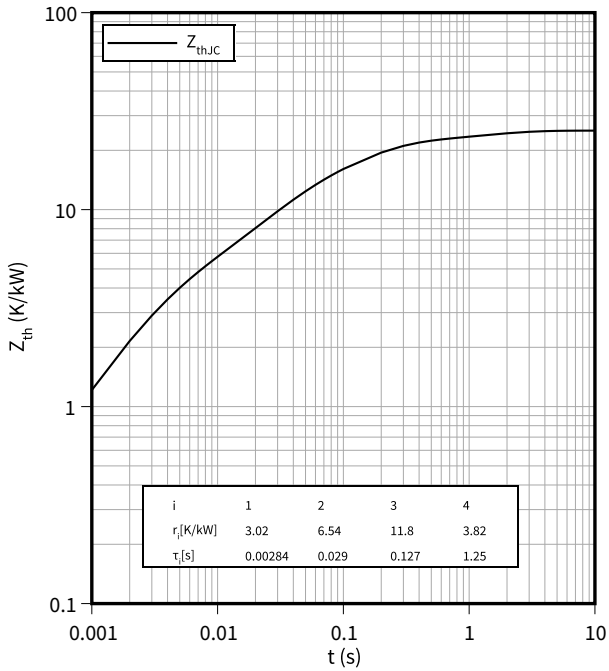

**Safe operating area (SOA), Diode, Inverter**

$I_R = f(V_R)$

$T_{vj} = 150\text{ °C}$

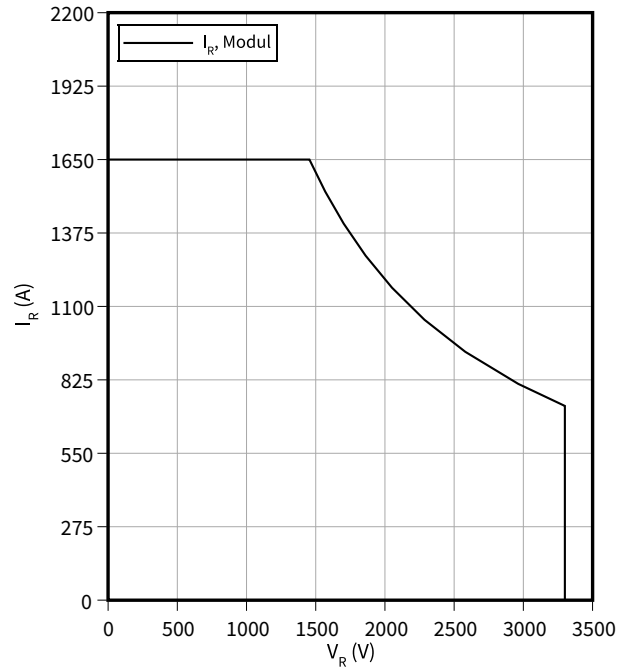

## 5 Circuit diagram

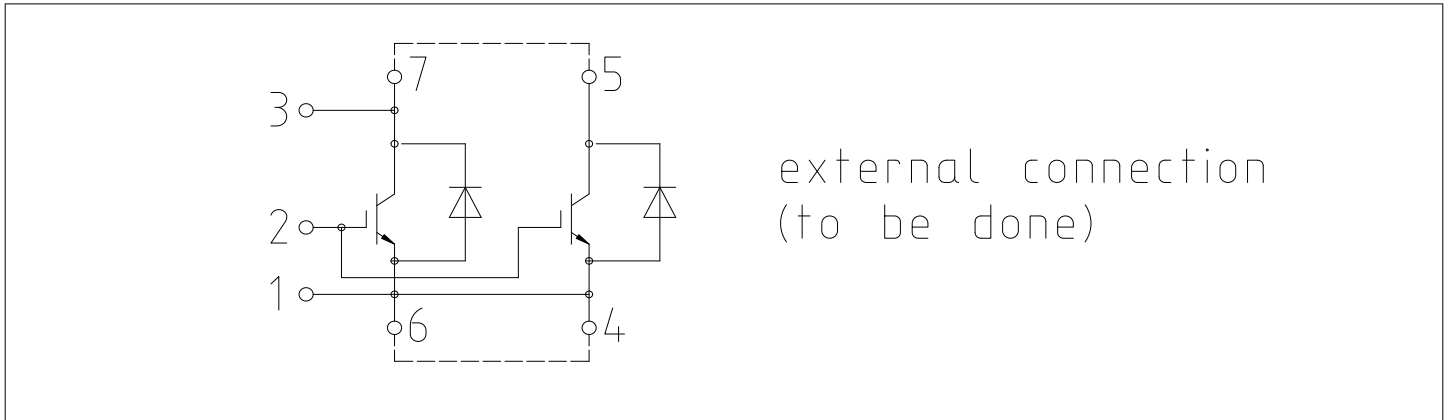

Figure 1

## 6 Package outlines

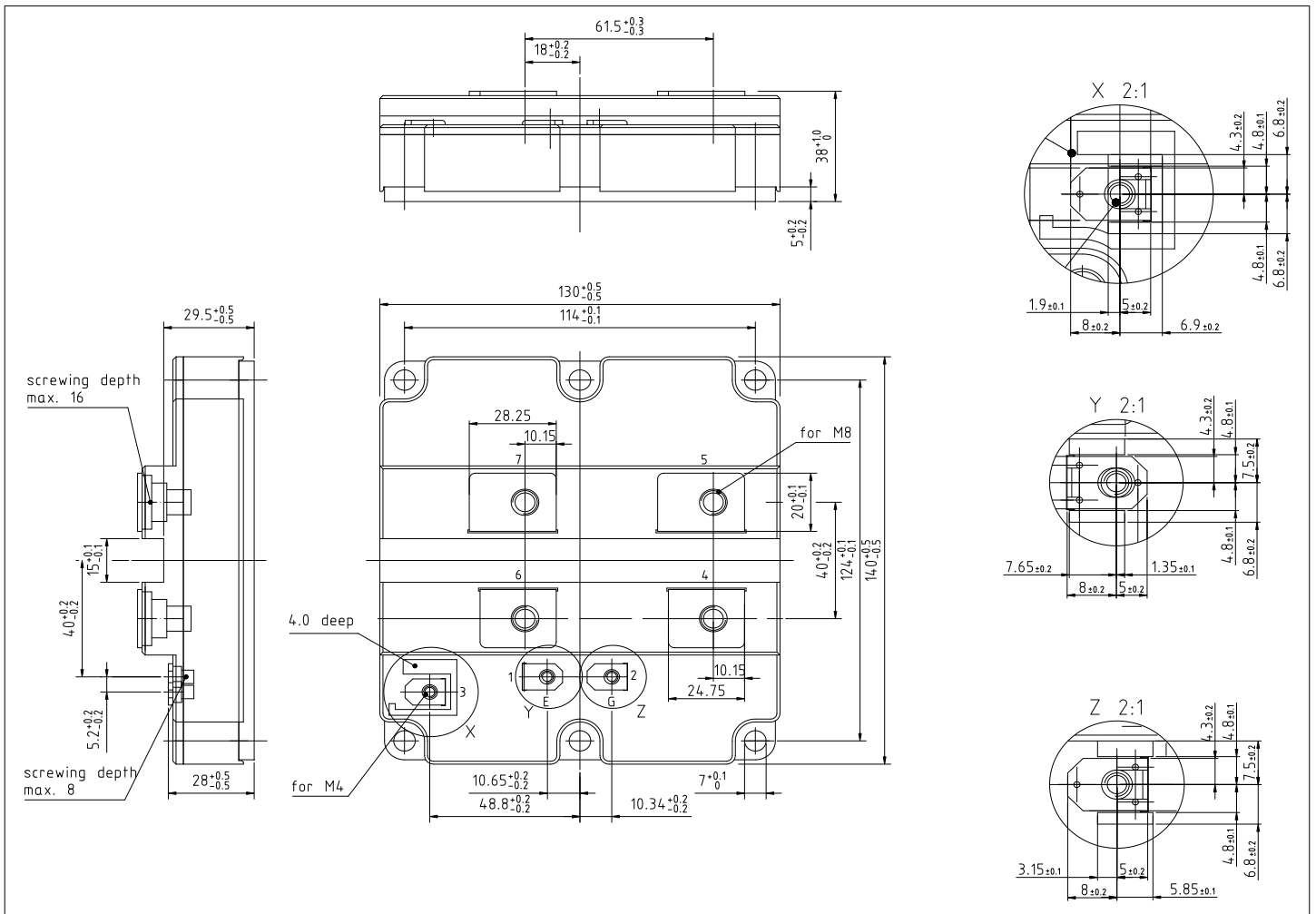

Figure 2

## 7 Module label code

Module label code			
Code format	Data Matrix	Barcode Code128	
Encoding	ASCII text	Code Set A	
Symbol size	16x16	23 digits	
Standard	IEC24720 and IEC16022	IEC8859-1	
Code content	<i>Content</i> Module serial number Module material number Production order number Date code (production year) Date code (production week)	<i>Digit</i> 1 - 5 6 - 11 12 - 19 20 - 21 22 - 23	<i>Example</i> 71549 142846 55054991 15 30
Example	<div style="display: flex; justify-content: space-around; align-items: center;"> <div style="text-align: center;">  71549142846550549911530                 </div> <div style="text-align: center;">  71549142846550549911530                 </div> </div>		

Figure 3

## Revision history

Document revision	Date of release	Description of changes
0.10	2020-12-17	
0.10	2021-01-28	
1.10	2021-03-16	
1.20	2021-10-15	Final datasheet
1.30	2022-11-22	Final datasheet

## Trademarks

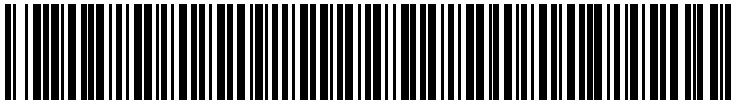
All referenced product or service names and trademarks are the property of their respective owners.

**Edition 2022-11-22**

**Published by**

**Infineon Technologies AG**

**81726 Munich, Germany**

**© 2022 Infineon Technologies AG**

**All Rights Reserved.**

**Do you have a question about any aspect of this document?**

**Email: [erratum@infineon.com](mailto:erratum@infineon.com)**

**Document reference**

**IFX-AAK420-005**

## Important notice

The information given in this document shall in no event be regarded as a guarantee of conditions or characteristics ("Beschaffheitsgarantie").

With respect to any examples, hints or any typical values stated herein and/or any information regarding the application of the product, Infineon Technologies hereby disclaims any and all warranties and liabilities of any kind, including without limitation warranties of non-infringement of intellectual property rights of any third party.

In addition, any information given in this document is subject to customer's compliance with its obligations stated in this document and any applicable legal requirements, norms and standards concerning customer's products and any use of the product of Infineon Technologies in customer's applications.

The data contained in this document is exclusively intended for technically trained staff. It is the responsibility of customer's technical departments to evaluate the suitability of the product for the intended application and the completeness of the product information given in this document with respect to such application.

Please note that this product is not qualified according to the AEC Q100 or AEC Q101 documents of the Automotive Electronics Council.

## Warnings

Due to technical requirements products may contain dangerous substances. For information on the types in question please contact your nearest Infineon Technologies office.

Except as otherwise explicitly approved by Infineon Technologies in a written document signed by authorized representatives of Infineon Technologies, Infineon Technologies' products may not be used in any applications where a failure of the product or any consequences of the use thereof can reasonably be expected to result in personal injury.