

Fast Diode Modules

AMKE 290F



V_{RSM} V	V_{RRM} V	$I_{FRMS} = 455$ A (maximum value for continuous operation) $I_{FAV} = 290$ A (sin. 180; 50 Hz; $T_C = 109^\circ\text{C}$)		
600	600	AMKE 290-F06		

Symbols and parameters			Values	Units
I_{FAV}	Mean forward current	sin 180; $T_C = 85$ (100) $^\circ\text{C}$	390 (330)	A
I_{FSM}	Surge forward current	$T_{vj} = 25^\circ\text{C}$; 10 ms $T_{vj} = 150^\circ\text{C}$; 10 ms	7000 6000	A A
i^2t	i^2t value, rating for fusing	$T_{vj} = 25^\circ\text{C}$; 8.3...10 ms $T_{vj} = 150^\circ\text{C}$; 8.3...10 ms	245000 180000	A^2s A^2s
V_F	Forward voltage	$T_{vj} = 25^\circ\text{C}$; $I_F = 400$ A	max. 1.45	V
$V_{(TO)}$	On-state threshold voltage	$T_{vj} = 150^\circ\text{C}$	max. 0.9	V
r_T	On-state slope resistance	$T_{vj} = 150^\circ\text{C}$	max. 1.2	$\text{m}\Omega$
I_{RD}	Direct reverse current	$T_{vj} = 25^\circ\text{C}$; $V_{RD} = V_{RRM}$ $T_{vj} = 150^\circ\text{C}$; $V_{RD} = V_{RRM}$	max. 0.4 max. 60	mA
Q_{rr}	Reverse recovery charge		33.5	μC
I_{RM}	Peak reverse recovery current	$T_{vj} = 125^\circ\text{C}$ $I_F = 300$ A	160	A
t_{rr}	Reverse recovery time	$di/dt_{off} = 1600$ A/ μs $V_R = 300$ V	580	ns
E_{rr}	Energy dissipation during reverse recovery		3.6	mJ
$R_{th(j-c)}$	Thermal resistance, junction to case		0.08	K/W
$R_{th(c-s)}$	Thermal resistance, junction to heatsink		0.05	K/W
T_{vj}	(Virtual) junction temperature		-40 ... +150	$^\circ\text{C}$
T_{stg}	Storage temperature range		-40 ... +125	$^\circ\text{C}$
V_{isol}	Insulation test voltage (r.m.s.)	a.c. 50 Hz; r.m.s.; 1s / 1min	3600 / 3000	V \sim
M_s	Mounting torque on heatsink		$5 \pm 15\%$	Nm
M_t	Mounting torque for terminals		$5 \pm 15\%$	Nm
a	Maximum allowable acceleration		$5 \cdot 9.81$	m/s^2
W	Weight		160	g

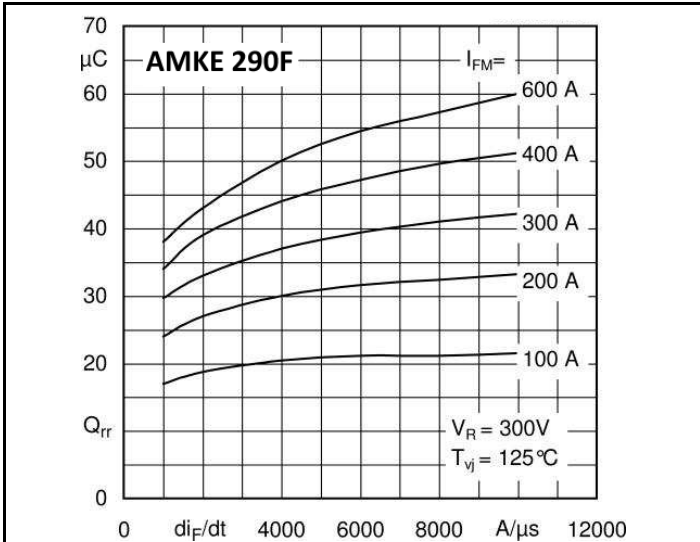

Fig. 1 Typ. recovery charge vs. current decrease

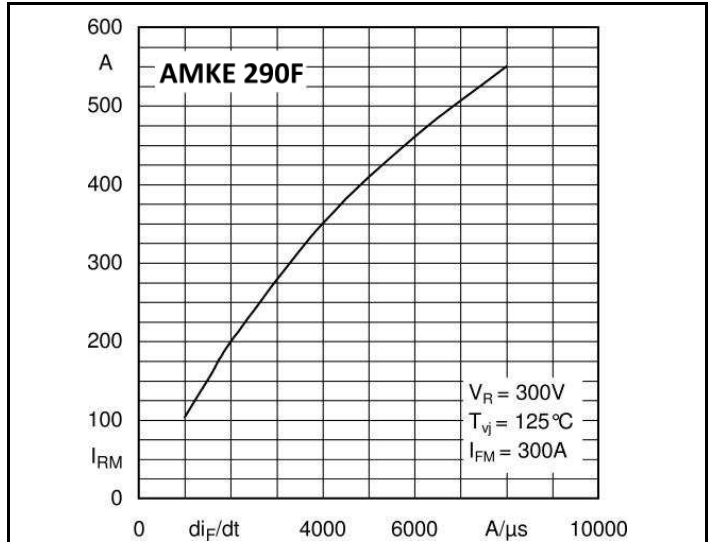

Fig. 2 Peak recovery current vs. current decrease

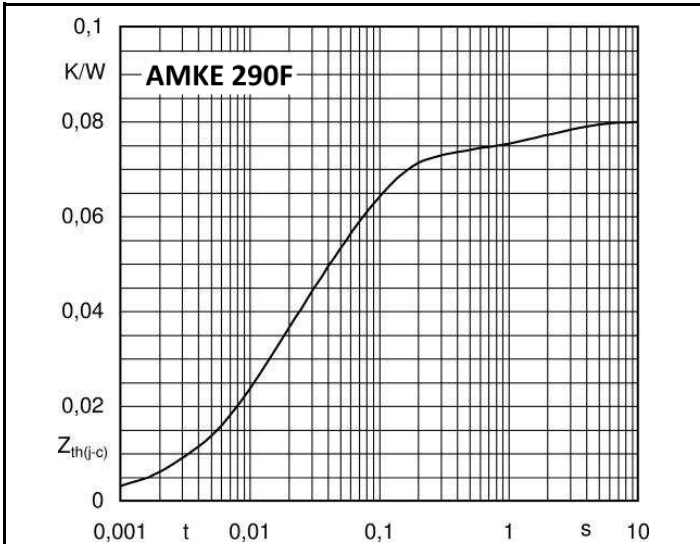

Fig. 3 Transient thermal impedance vs. time

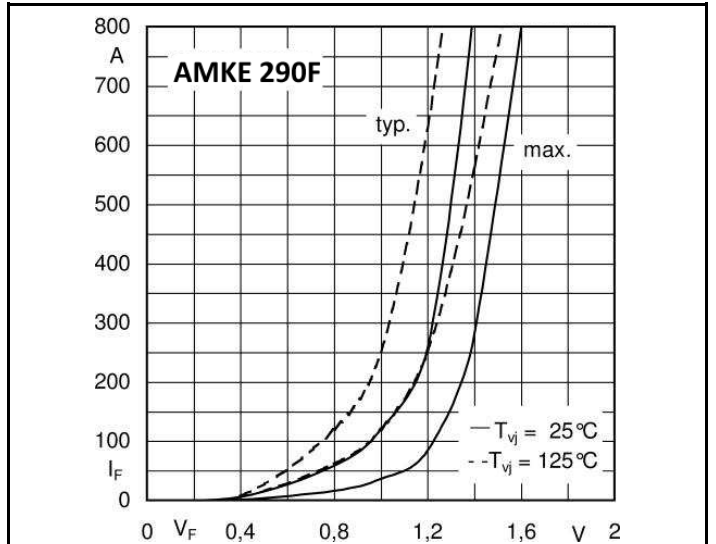

Fig. 4 Forward characteristics

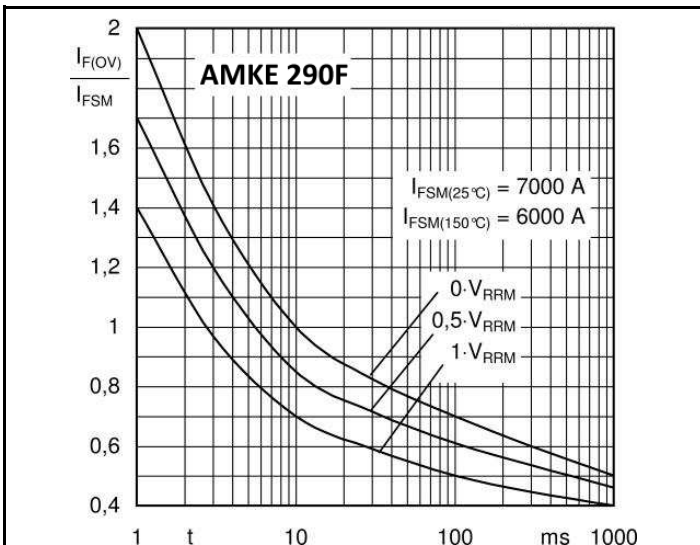
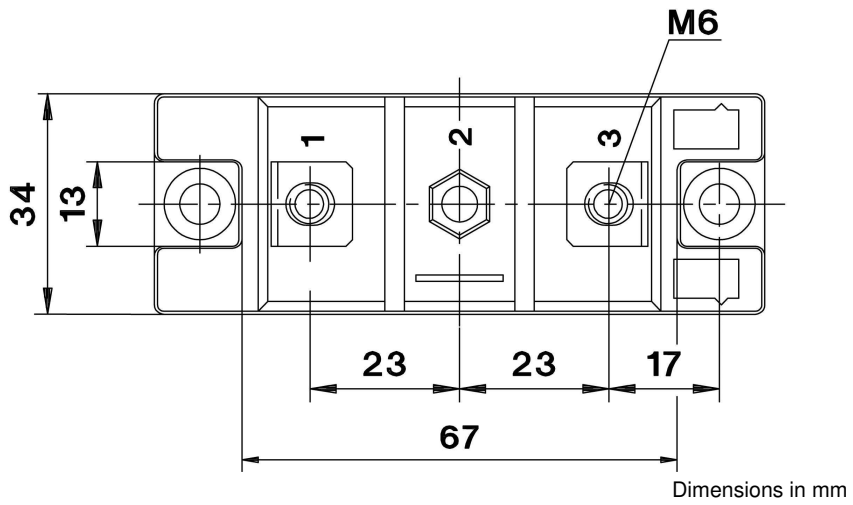
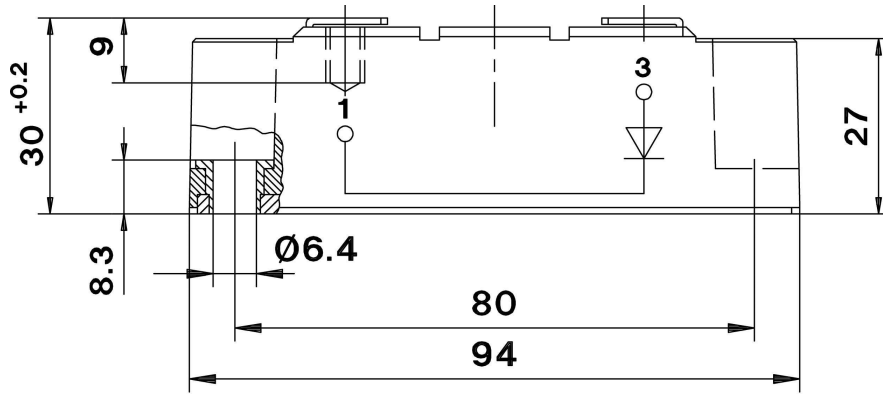

Fig. 5 Surge overload current vs. time

DIMENSIONS



TOPOLOGY OF INTERNAL CONNECTION

