

TG 919-1600-45

Gate Turn-off Thyristor

Properties

- Full reverse voltage
- High reliability
- Suitable for drives and traction applications

Key Parameters

V_{DRM}, V_{RRM}	=	4 500	V
I_{TGQM}	=	1 600	A
I_{TAVm}	=	600	A
I_{TSM}	=	12 000	A
V_{TO}	=	2.306	V
r_T	=	1.301	mΩ

Types

	V_{DRM}, V_{RRM}
TG 919-1600-45	4 500 V
TG 919-1600-40	4 000 V
TG 919-1600-36	3 600 V
Conditions:	$T_j = -40 \div 115 \text{ }^\circ\text{C}$, half sine waveform, $f = 50\text{Hz}$

Mechanical Data

F_m	Mounting force	15 ± 3 kN
m	Weight	0.82 kg
D_s	Surface creepage distance	25 mm
D_a	Air strike distance	13 mm

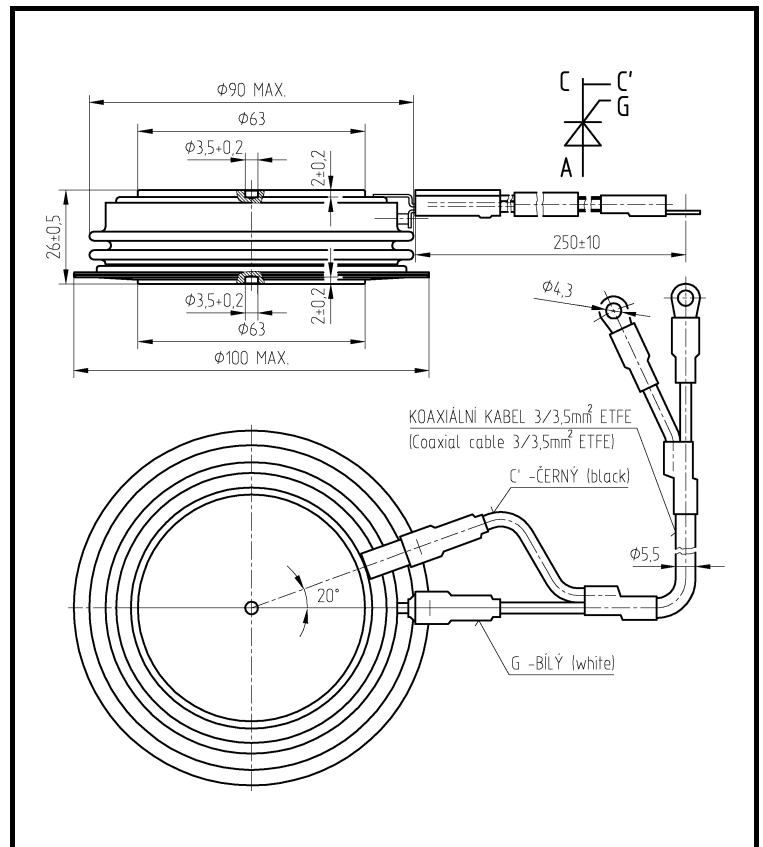

Fig. 1 Case

Polovodice, a.s.

Novodvorska 1768/138a, 142 21 Praha 4, Czech Republic

tel.: +420 261 306 357 fax: +420 261 306 307, <http://www.polovodice.cz>

Maximum Ratings			Maximum Limits	Unit
V_{DRM} V_{RRM}	Repetitive peak off-state and peak reverse voltage $T_j = -40 \div 115 \text{ }^\circ\text{C}$, $V_{GK} = -2 \text{ V}$	TG 919-1600-45 TG 919-1600-40 TG 919-1600-36	4 500 4 000 3 600	V
I_{TGQM}	Peak Turn-off current $T_j = -40 \div 115 \text{ }^\circ\text{C}$, $C_S = 4 \text{ }\mu\text{F}$, $di_{GC}/dt = -35 \text{ A}/\mu\text{s}$, $V_{DM} = 0.8 V_{DRM}$		1 600	A
I_{TRMS}	RMS on-state current $T_c = 70 \text{ }^\circ\text{C}$, <i>half sine waveform</i> , $f = 50 \text{ Hz}$		940	A
I_{TAVm}	Average on-state current $T_c = 70 \text{ }^\circ\text{C}$, <i>half sine waveform</i> , $f = 50 \text{ Hz}$		600	A
I_{TSM}	Peak non-repetitive surge <i>half sine pulse</i> , $t_p = 10 \text{ ms}$, $V_R = 0 \text{ V}$		12 000	A
I^2t	Limiting load integral <i>half sine pulse</i> , $t_p = 10 \text{ ms}$, $V_R = 0 \text{ V}$		720 000	A²s
$(di_T/dt)_{cr}$	Critical rate of rise of on-state current $I_T = I_{TGQM}$, $V_D = 2/3 V_{DRM}$, $f = 50 \text{ Hz}$		400	A/μs
$(dv_D/dt)_{cr}$	Critical rate of rise of off-state voltage $V_D = 2/3 V_{DRM}$, $V_{GC} = -2 \text{ V}$		1 000	V/μs
V_{DSP}	Peak turn-off voltage spike due to snubber		500	V
I_{FGCM}	Peak forward gate current		80	A
I_{GCMS}	RMS gate current		63	A
V_{GCM}	Peak reverse gate voltage		-16	V
$t_{on(min)}$	Minimum permissible on-time		50	μs
$t_{off(min)}$	Minimum permissible off-time		100	μs
$T_{jmin} - T_{jmax}$	Operating temperature range		-40 \div 115	$^\circ\text{C}$
$T_{stgmin} - T_{stgmax}$	Storage temperature range		-40 \div 115	$^\circ\text{C}$

Unless otherwise specified $T_j = 115 \text{ }^\circ\text{C}$

Type of GTO Thyristor	Recommended Diodes	
	SNUBBER	FREEWHEEL
TG 919-1600-45	DM 827-500-45	DM 827-500-45
TG 919-1600-40	DM 827-500-40	DM 827-500-40
TG 919-1600-36	DM 827-500-36	DM 827-500-36

Polovodice, a.s., Novodvorska 1768/138a, 142 21 Praha 4, Czech Republic

Characteristics		Value			Unit
		min.	typ.	max.	
V_{TM}	Maximum peak on-state voltage $I_{GT} = 2A, I_{TM} = 1\ 600\ A$			4.450	V
V_{T0}	Threshold voltage			2.306	V
r_T	Slope resistance $I_{T1} = 667\ A, I_{T2} = 2\ 000\ A$			1.301	mΩ
I_L	Latching current $T_j = 25\ ^\circ C$			120	A
I_{DM}	Peak off-state current $V_D = V_{DRM}, V_{GC} = -2\ V$			150	mA
I_{RM}	Peak reverse current $V_R = V_{RRM}$			150	mA
I_{GCM}	Peak negative gate leakage current $V_{GC} = -16\ V$			50	mA
V_{GT}	Gate trigger voltage $T_j = -40 \div 115\ ^\circ C$			1.5	V
I_{GT}	Gate trigger current $V_D = 12\ V, R_L = 0.1\ \Omega$	$T_j = -40\ ^\circ C$ $T_j = 25\ ^\circ C$ $T_j = 125\ ^\circ C$		16 1.6 0.8	A
t_f	Fall time	<i>Definitions as on Fig.9</i> $V_D = 2/3\ V_{DRM},$ $I_{TGO} = I_{TGO}, C_S = 4\ \mu F,$ $V_{GC} = -15\ V,$ $di_{GC}/dt = -35\ A/\mu s$		1.5	μs
t_s	Storage time			14.5	
t_{gq}	Turn-off time			18	
t_{tail}	Tail time			30	

Unless otherwise specified $T_j = 115\ ^\circ C$

Thermal Parameters		Value	Unit
R_{thjc}	Thermal resistance junction to case <i>double side cooling</i>	18	K/kW
R_{thch}	Thermal resistance case to heatsink, <i>double side cooling</i>	6	K/kW

Transient Thermal Impedance

Analytical function for transient thermal impedance

$$Z_{thjc} = \sum_{i=1}^5 R_i (1 - \exp(-t/\tau_i))$$

Conditions:
 $F_m = 15 \pm 3$ kN, Double side cooled

<i>i</i>	1	2	3	4	5
R_i (K/kW)	7.32	0.63	5.74	4.10	0.21
τ_i (s)	0.5526	0.2048	0.0913	0.0170	0.0003

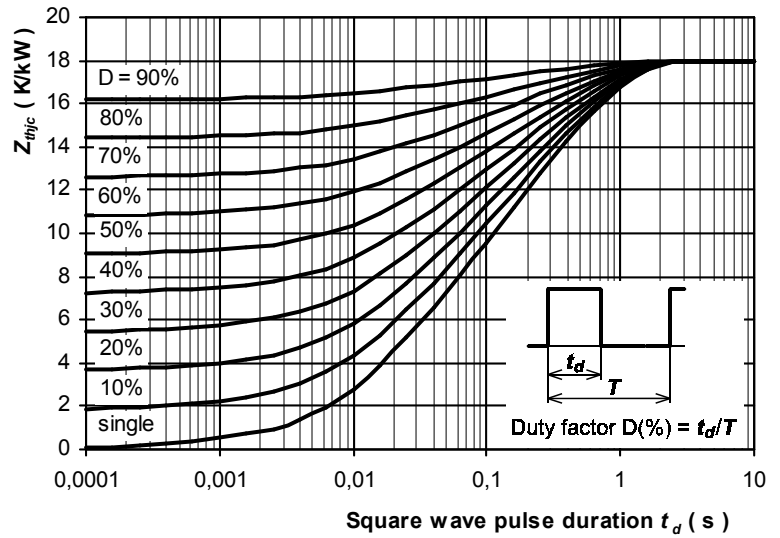

Fig.2 Transient thermal impedance junction to case (Double side cooled)

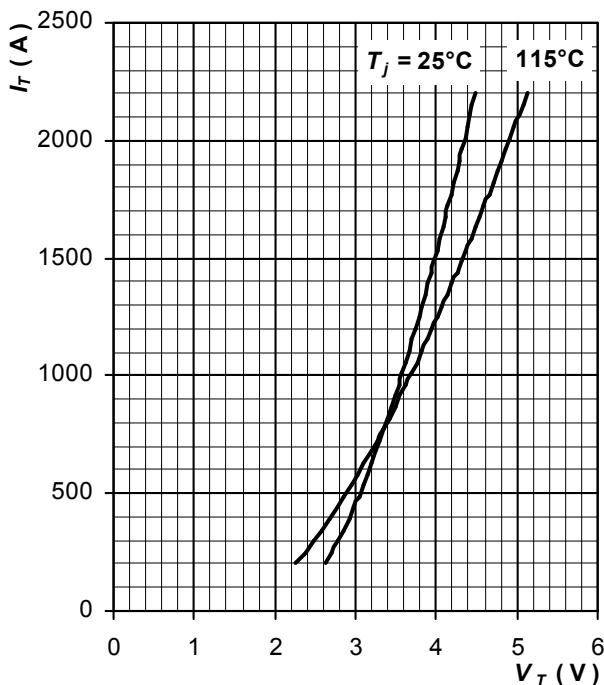

Fig.3 Maximum instantaneous on-state characteristics

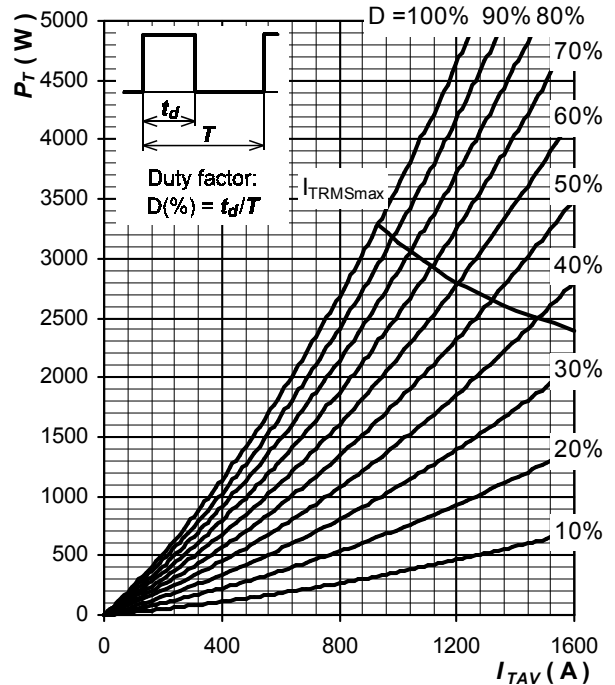

Fig.4 Power losses vs Rectangular pulse current

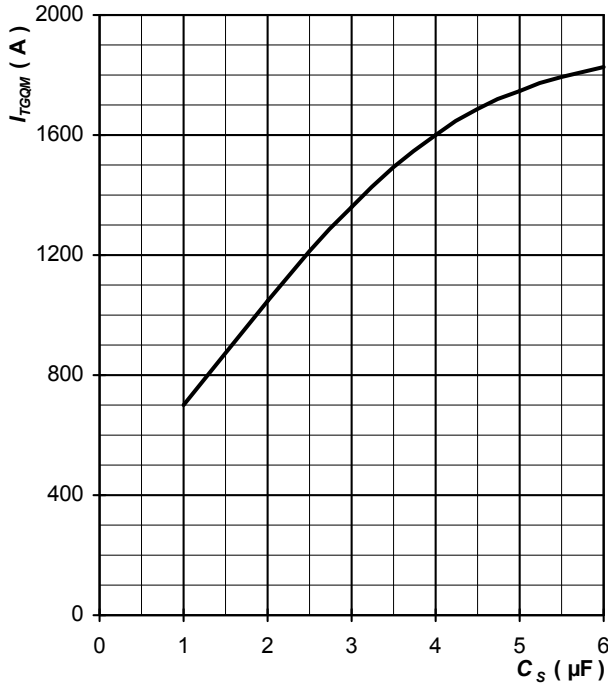

Fig.5 Maximum permissible turn-off current vs Snubber capacitance

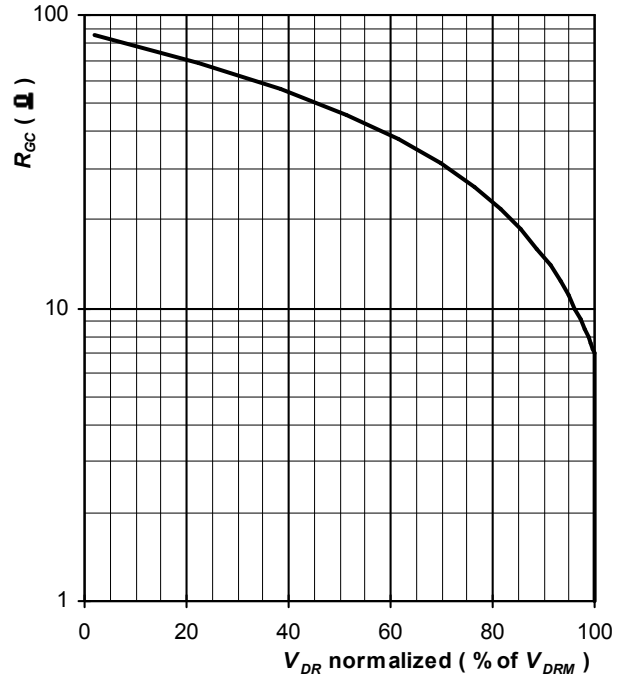

Fig.6 Maximum forward blocking voltage vs External gate-cathode resistance

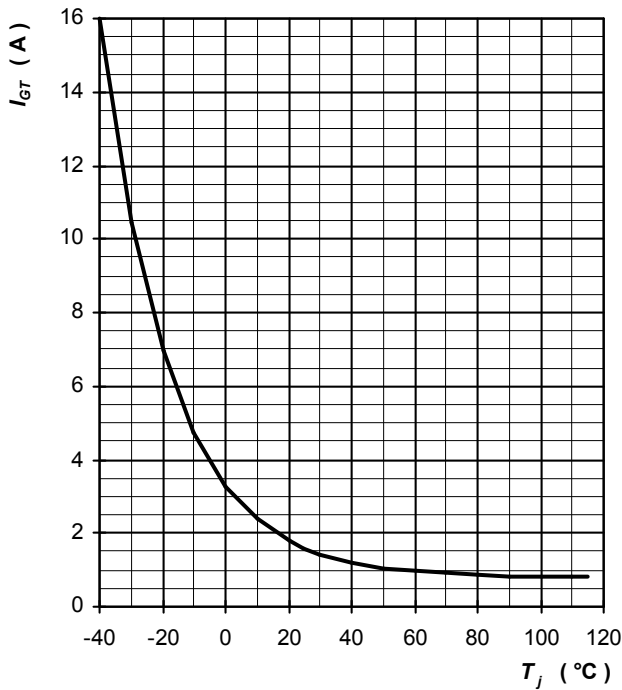

Fig.7 Maximum gate trigger current vs Junction temperature

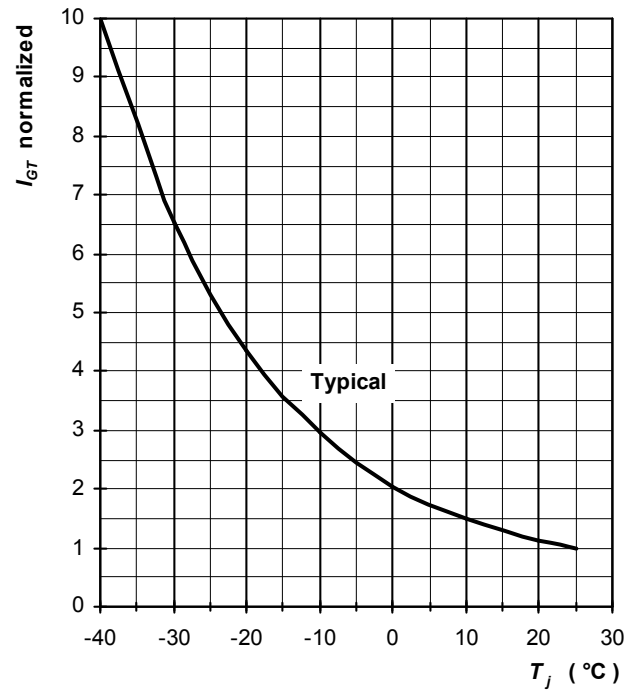

Fig.8 Gate trigger current normalized to I_{GT} by 25°C vs Junction temperature

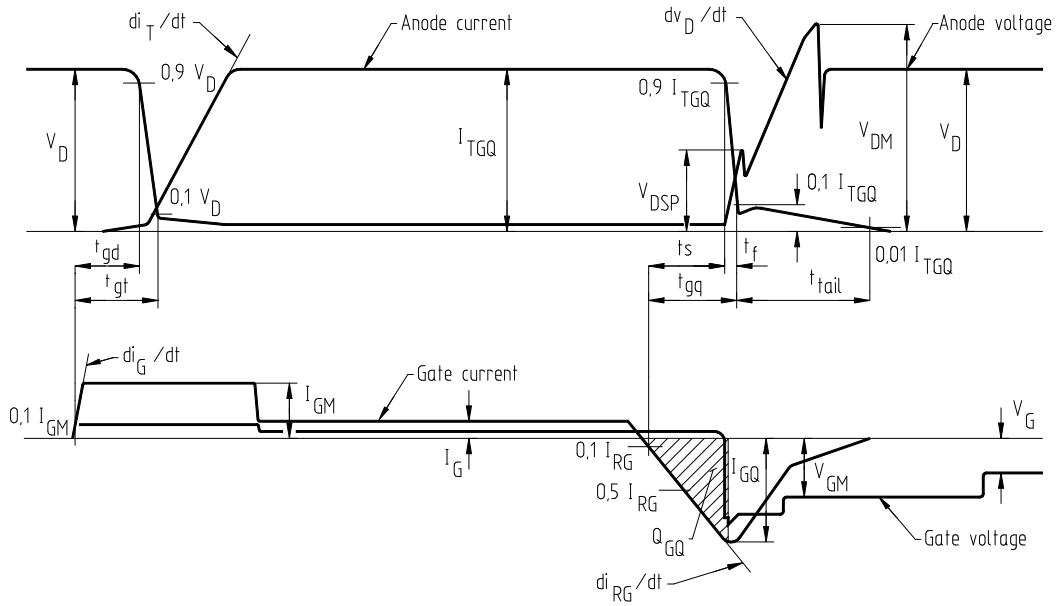

Fig.9 Turn-off waveform diagram

Notes