

TG 907-800-30

Gate Turn-off Thyristor

Properties

- Full reverse voltage
- High reliability
- Suitable for drives and traction applications

Key Parameters

V_{DRM}, V_{RRM}	=	3 000	V
I_{TGQM}	=	800	A
I_{TAVm}	=	395	A
I_{TSM}	=	4 500	A
V_{TO}	=	1.633	V
r_T	=	1.908	mΩ

Types

	V_{DRM}, V_{RRM}
TG 907-800-30	3 000 V
TG 907-800-25	2 500 V
TG 907-800-20	2 000 V
Conditions: $T_j = -40 \div 125 \text{ }^\circ\text{C}$, half sine waveform, $f = 50\text{Hz}$	

Mechanical Data

F_m	Mounting force	5 ± 1 kN
m	Weight	0.3 kg
D_s	Surface creepage distance	25 mm
D_a	Air strike distance	13 mm

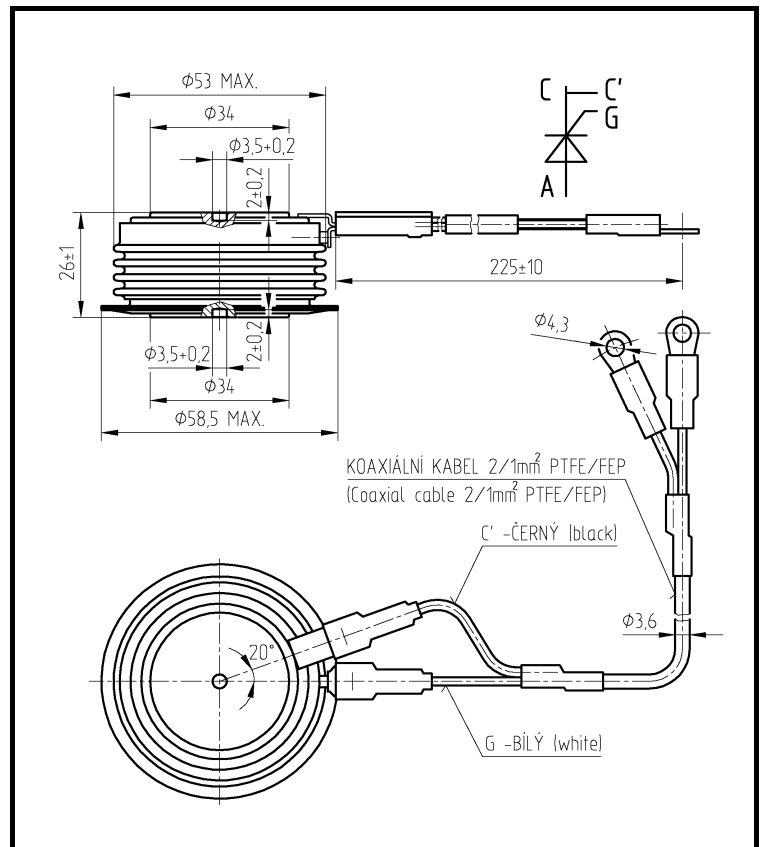

Fig. 1 Case

Polovodice, a.s.

Novodvorska 1768/138a, 142 21 Praha 4, Czech Republic

tel.: +420 261 306 357 fax: +420 261 306 307, <http://www.polovodice.cz>

Maximum Ratings			Maximum Limits	Unit
V_{DRM} V_{RRM}	Repetitive peak off-state and peak reverse voltage $T_j = -40 \div 125 \text{ }^\circ\text{C}$, $V_{GK} = -2 \text{ V}$	TG 907-800-30 TG 907-800-25 TG 907-800-20	3 000 2 500 2 000	V
I_{TGQM}	Peak Turn-off current $T_j = -40 \div 125 \text{ }^\circ\text{C}$, $C_S = 2 \text{ } \mu\text{F}$, $di_G/dt = -25 \text{ A}/\mu\text{s}$, $V_{DM} = 0.8 V_{DRM}$		800	A
I_{TRMS}	RMS on-state current $T_c = 70 \text{ }^\circ\text{C}$, half sine waveform, $f = 50 \text{ Hz}$		620	A
I_{TAVm}	Average on-state current $T_c = 70 \text{ }^\circ\text{C}$, half sine waveform, $f = 50 \text{ Hz}$		395	A
I_{TSM}	Peak non-repetitive surge half sine pulse, $t_p = 10 \text{ ms}$, $V_R = 0 \text{ V}$		4 500	A
I^2t	Limiting load integral half sine pulse, $t_p = 10 \text{ ms}$, $V_R = 0 \text{ V}$		101 250	A ² s
$(di_T/dt)_{cr}$	Critical rate of rise of on-state current $I_T = I_{TGQM}$, $V_D = 2/3 V_{DRM}$, $f = 50 \text{ Hz}$		400	A/ μs
$(dv_D/dt)_{cr}$	Critical rate of rise of off-state voltage $V_D = 2/3 V_{DRM}$, $V_{GC} = -2 \text{ V}$		1 000	V/ μs
V_{DSP}	Peak turn-off voltage spike due to snubber		500	V
I_{FGCM}	Peak forward gate current		30	A
I_{GCMS}	RMS gate current		25	A
V_{GCM}	Peak reverse gate voltage		-16	V
$t_{on(min)}$	Minimum permissible on-time		50	μs
$t_{off(min)}$	Minimum permissible off-time		100	μs
$T_{jmin} - T_{jmax}$	Operating temperature range		-40 \div 125	$^\circ\text{C}$
$T_{stgmin} - T_{stgmax}$	Storage temperature range		-40 \div 125	$^\circ\text{C}$

Unless otherwise specified $T_j = 125 \text{ }^\circ\text{C}$

Type of GTO Thyristor	Recommended Diodes	
	SNUBBER	FREEWHEEL
TG 907-800-20	DM 839-100-20	DM 856-400-20
TG 907-800-25	DM 839-100-25	DM 856-400-25
TG 907-800-30	DM 827-500-36	DM 827-500-36

Polovodice, a.s., Novodvorska 1768/138a, 142 21 Praha 4, Czech Republic

Polovodice, a.s. reserves the right to change the data contained herein at any time without notice

Characteristics		Value			Unit
		<i>min.</i>	<i>typ.</i>	<i>max.</i>	
V_{TM}	Maximum peak on-state voltage $I_{GT} = 2 \text{ A}, I_{TM} = 800 \text{ A}$			3.200	V
V_{T0}	Threshold voltage			1.633	V
r_T	Slope resistance $I_{T1} = 333 \text{ A}, I_{T2} = 1\,000 \text{ A}$			1.908	mΩ
I_L	Latching current $T_j = 25 \text{ }^\circ\text{C}$			40	A
I_{DM}	Peak off-state current $V_D = V_{DRM}, V_{GC} = -2 \text{ V}$			50	mA
I_{RM}	Peak reverse current $V_R = V_{RRM}$			50	mA
I_{GCM}	Peak negative gate leakage current $V_{GC} = -16 \text{ V}$			50	mA
V_{GT}	Gate trigger voltage $T_j = -40 \div 125 \text{ }^\circ\text{C}$			1.5	V
I_{GT}	Gate trigger current $V_D = 12 \text{ V}, R_L = 0.1 \text{ } \Omega$	$T_j = -40 \text{ }^\circ\text{C}$ $T_j = 25 \text{ }^\circ\text{C}$ $T_j = 125 \text{ }^\circ\text{C}$		4.0 1.0 0.6	A
t_f	Fall time	<i>Definitions as on Fig.9</i> $V_D = 2/3 V_{DRM},$ $I_{TQG} = I_{TQGM}, C_S = 2 \text{ } \mu\text{F},$ $V_{GC} = -15 \text{ V},$ $di_{GC}/dt = -25 \text{ A}/\mu\text{s}$		1.5	μs
t_s	Storage time			12.5	
t_{gq}	Turn-off time			12	
t_{tail}	Tail time			30	

Unless otherwise specified $T_j = 125 \text{ }^\circ\text{C}$

Thermal Parameters		Value	Unit
R_{thjc}	Thermal resistance junction to case <i>double side cooling</i>	40	K/kW
R_{thch}	Thermal resistance case to heatsink, <i>double side cooling</i>	12	K/kW

Transient Thermal Impedance

Analytical function for transient thermal impedance

$$Z_{thjc} = \sum_{i=1}^4 R_i (1 - \exp(-t / \tau_i))$$

Conditions:
 $F_m = 5 \pm 1$ kN, Double side cooled

<i>i</i>	1	2	3	4
R_i (K/kW)	11.51	7.72	13.47	7.31
τ_i (s)	0.4201	0.1900	0.0592	0.0140

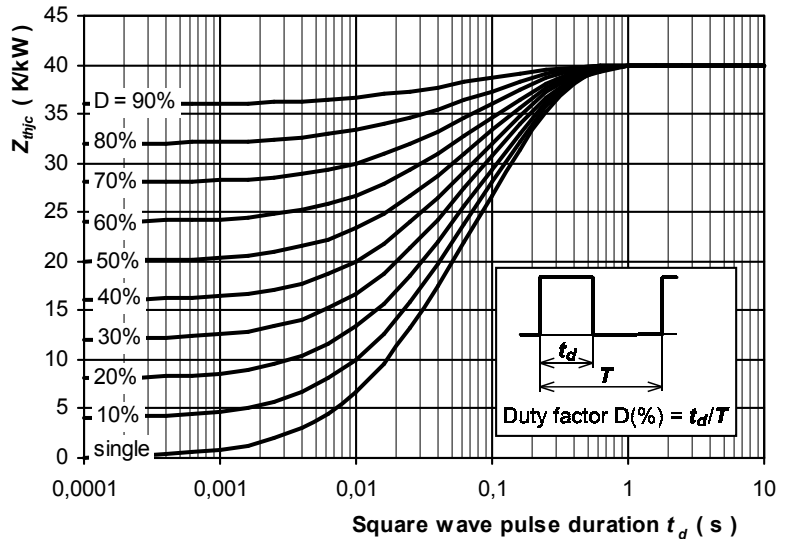

Fig.2 Transient thermal impedance junction to case (Double side cooled)

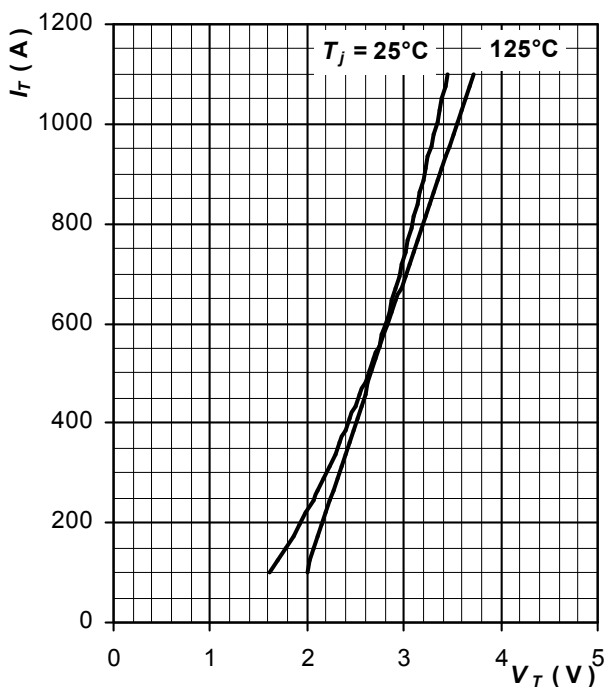

Fig.3 Maximum instantaneous on-state characteristics

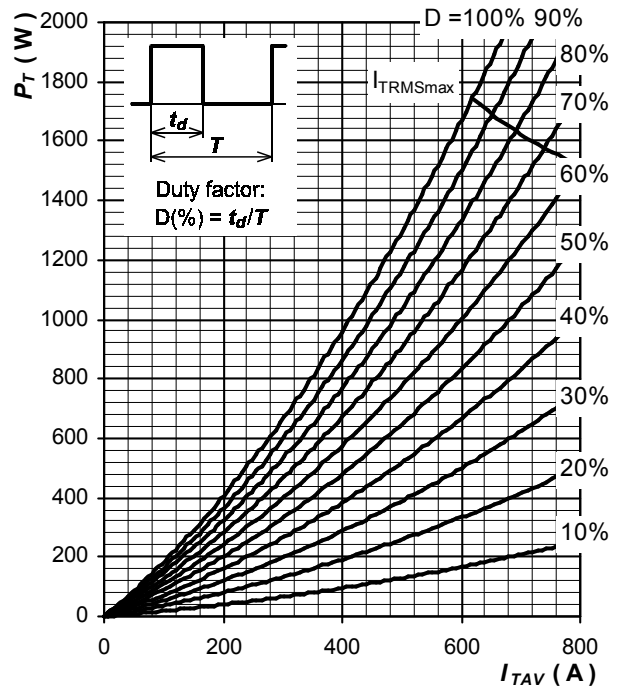

Fig.4 Power losses vs Rectangular pulse current

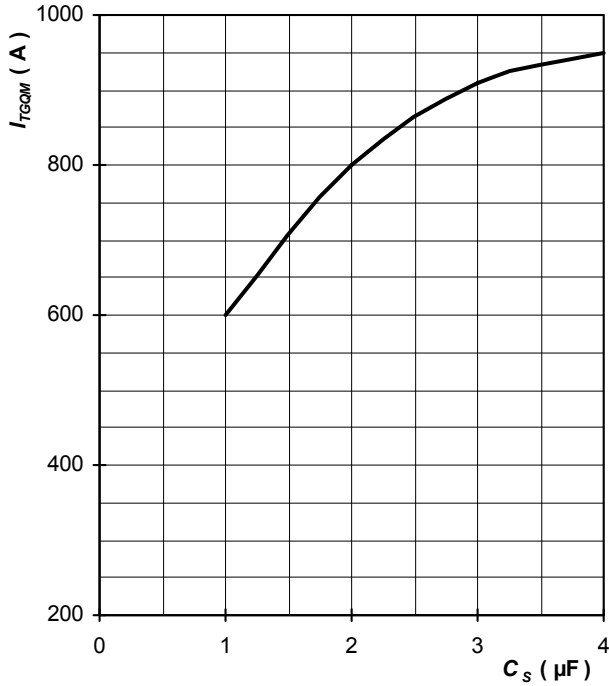

Fig.5 Maximum permissible peak turn-off current vs snubber capacitance

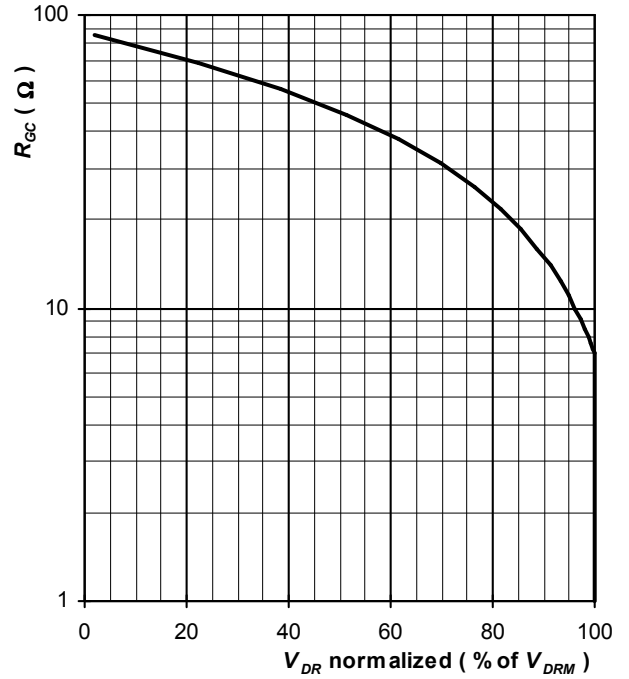

Fig.6 Maximum forward blocking voltage vs External gate-cathode resistance

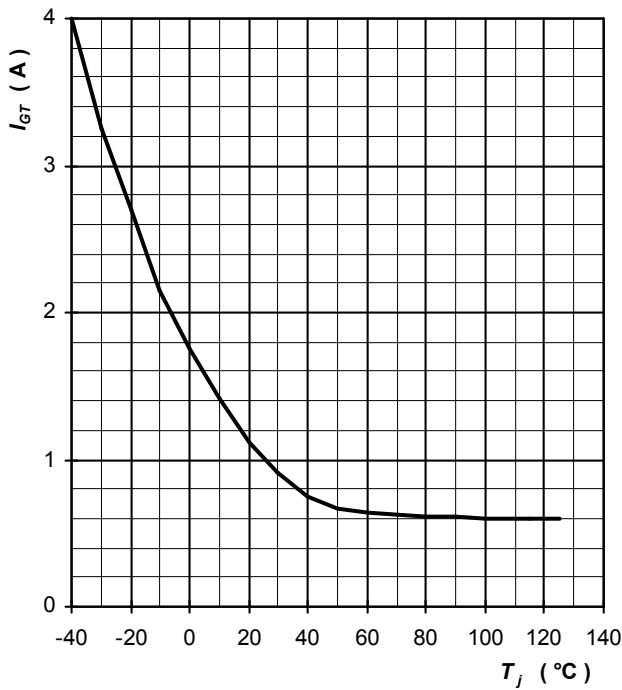

Fig.7 Maximum gate trigger current vs Junction temperature

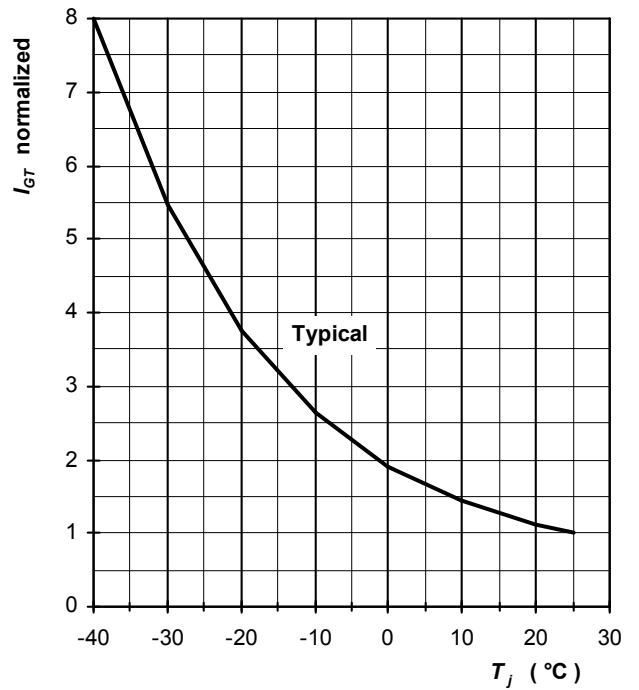

Fig.8 Gate trigger current normalized to I_{GT} by 25 $^{\circ}\text{C}$ vs Junction temperature

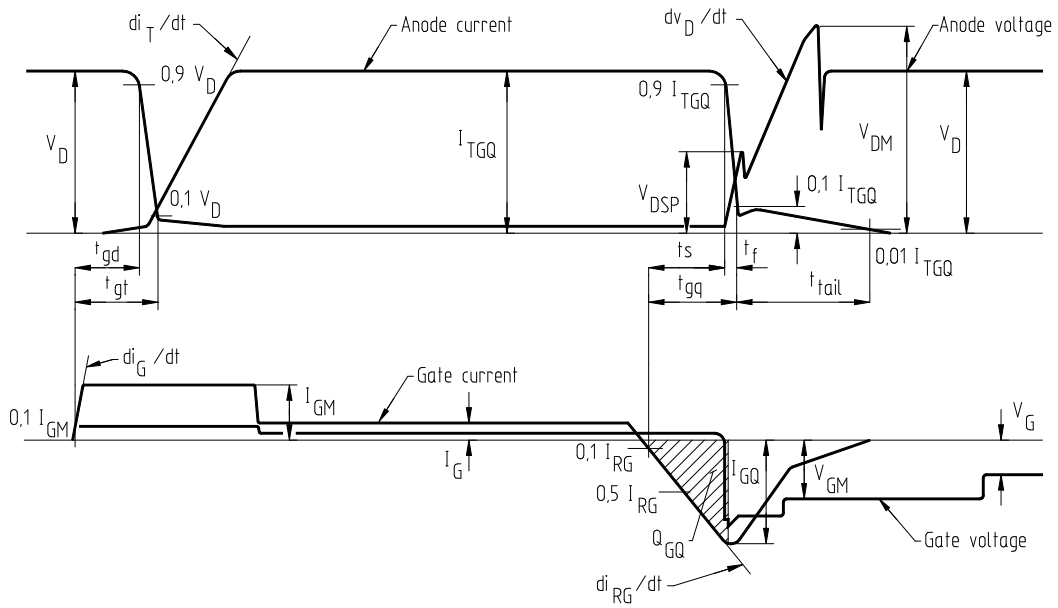

Fig.9 Turn-off waveform diagram

Notes