

Thyristors type T71 are of modern design with internal spring loaded contacts, high alumina ceramic insulator and pressure welding encapsulation. Designed for use in power electronic circuits and equipment under normal operating conditions.

KEY PARAMETERS

U_{DRM}, U_{RRM}	up to 2400 V
$I_{T(AV)}$	300 A
I_{TSM}	7600 A
du/dt^*	1000 V/μs
di/dt	100 A/μs

* maximum (non standard) value

FEATURES

- all diffused design
- high current capabilities
- high surge current capabilities
- high rates voltages
- high du/dt
- low gate current
- dynamic gate
- low thermal impedance
- tested according to IEC standards
- compact size and small weight

APPLICATION

- High Power Drives
- DC Motor Control
- High Voltage Power Supplies

Designed for use in high power industrial and commercial power electronic circuits and equipment where high currents are encountered and high reliability is essential.

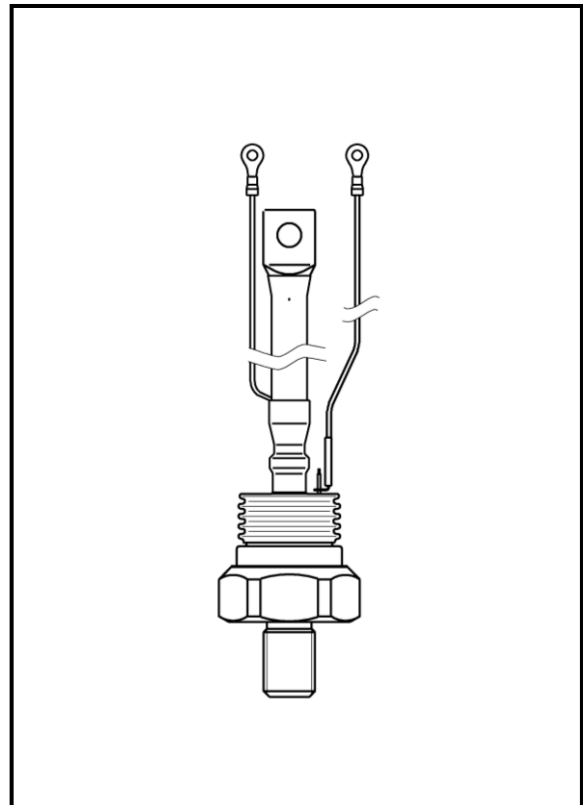

**Outline based on JEDEC TO-209AE
(TO-118)**

See package details for further information

ORDERING INFORMATION

When ordering please refer to device code builder presented below.
 Please use the complete part number when ordering, quote or in any future correspondence relating to your order.

T71-300-□□



This is standard device, with no dynamic parameters specified and standard accessory set.
 Please refer to **Electrical Parameters** if specific dynamic demands have to be met.
 Those information, as well as any other concerning non-standard accessories e.g. stud thread, custom leads lenght or lead terminal connector type should be included in the order.

ELECTRICAL PARAMETERS

Voltage ratings

Voltage class	U_{DRM}, U_{RRM}	U_{DSM}, U_{RSM}	I_{DRM}, I_{RRM}
	V	V	mA
04	400	500	33
06	600	700	
08	800	900	
10	1000	1100	
12	1200	1300	
14	1400	1500	
16	1600	1700	
18	1800	1900	
20	2000	2100	
22	2200	2300	
24	2400	2500	

du/dt group codes

Group code	du/dt
	V/μs
0	no specified value
4	200
5	320
6	500
7	1000

Electrical properties

Parameter		Unit	Test conditions	Value
Average on-state current	$I_{T(AV)}$	A		300
Case temperature	T_C	°C		70
RMS on-state current	$I_{T(RMS)}$	A		470
Surge current	I_{TSM}	A	$T_j=125^\circ\text{C}$, $U_R=0,8U_{RRM}$, $t_p=10\text{ms}$	7600
I^2t – value	I^2t	kA^2s		290
On-state voltage max.	U_{TM}	V	$T_j=25^\circ\text{C}$, $I_{TM}=625\text{A}$	2,20
Threshold voltage	$U_{T(T0)}$	V		1,02
Slope resistance	r_T	$\text{m}\Omega$		0,80
Latching current	I_l	mA	$T_j=25^\circ\text{C}$, $U_D=12\text{V}$	800
Holding current	I_H	mA	$T_j=25^\circ\text{C}$, $U_D=12\text{V}$	200
Circuit commutated turn-off time (typical)	t_q	μs	$T_j=125^\circ\text{C}$, $I_{TM}=250\text{A}$, $di_R/dt=25\text{A}/\mu\text{s}$, $du/dt=20\text{V}/\mu\text{s}$, $U_D=0,67U_{DRM}$, $U_{RM}=100\text{V}$	250
Turn-On time (typical)	t_{on}	μs	$I_{TM}=100\text{A}$, $U_{DM}=100\text{V}$	12
Rate of rise of on-state current-repetitive	di/dt	$\text{A}/\mu\text{s}$	$T_j=125^\circ\text{C}$, $I_{TM}=3I_{T(AV)}$, $U_D=0,67U_{DRM}$, $f=50\text{Hz}$, $I_{GM}=1\text{A}$, $di_G/dt=1\text{A}/\mu\text{s}$	100
Critical rate of raise of off-state voltage	du/dt	$\text{V}/\mu\text{s}$	$T_j=125^\circ\text{C}$, $U_D=0,67U_{DRM}$,	200 - 1000
Gate current to trigger	I_{GT}	mA	$T_j=25^\circ\text{C}$, $U_D=12\text{V}$	200
Gate voltage to trigger	U_{GT}	V	$T_j=25^\circ\text{C}$, $U_D=12\text{V}$	3

Thermal properties

Parameter		Unit	Test conditions	Value
Thermal resistance, junction to case	R_{thJC}	°C/W	DC	0,10
Thermal resistance, case to heatsink	R_{thCS}	°C/W		0,05
Operating junction temperature	$T_{jmin} \dots T_{jmax}$	°C		-40...+125
Storage temperature	T_{stg}	°C		-40...+125

Mechanical properties

Parameter		Unit	Value
Mounting torque	M	Nm	38 ... 41
Weight	m	g	530

Package details

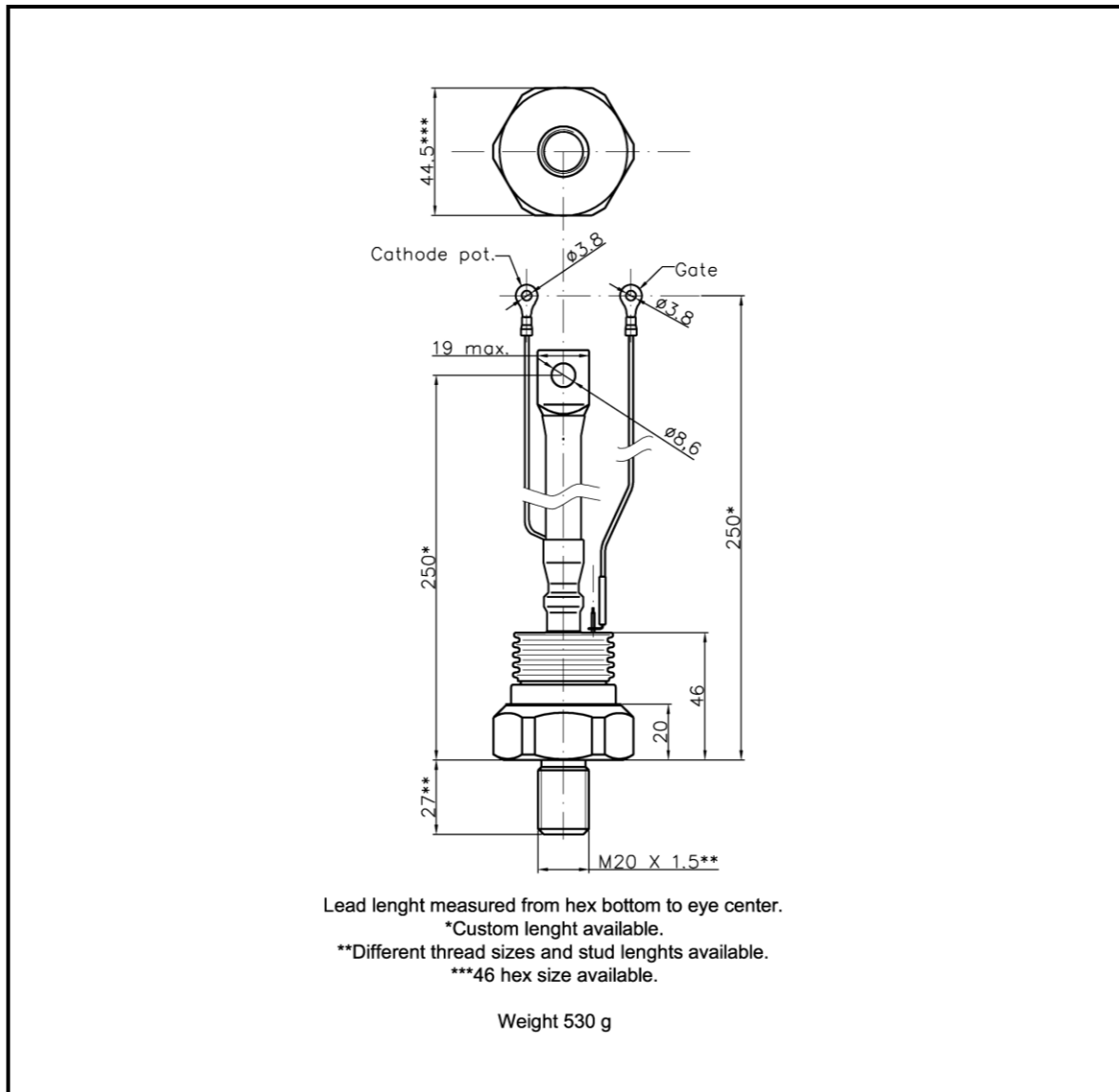

For further package information, please contact Sales & Marketing Department. All dimensions in mm, unless stated otherwise.
Do not scale.

CHARACTERISTICS

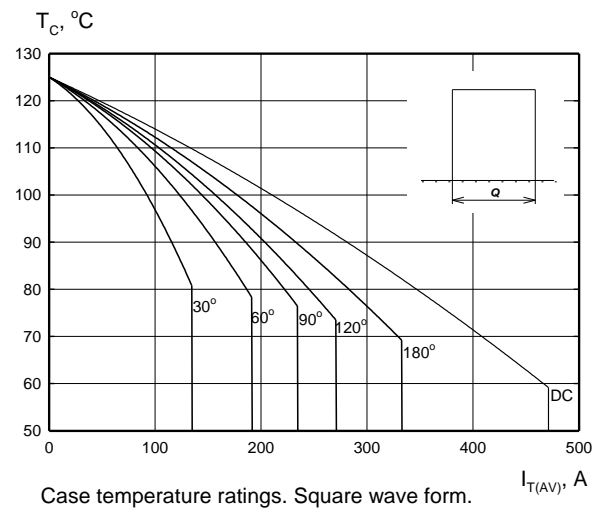
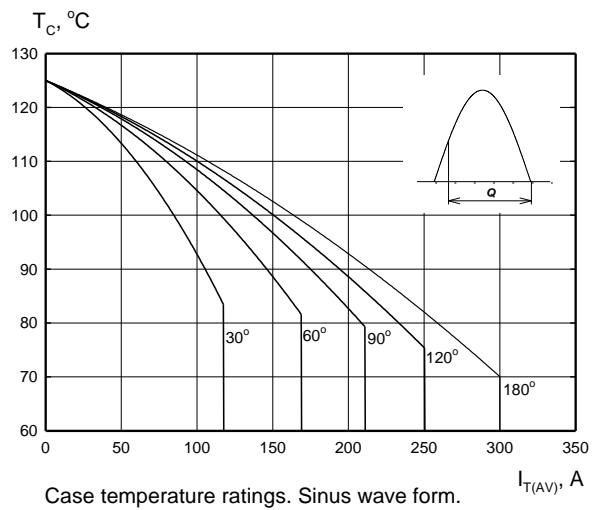
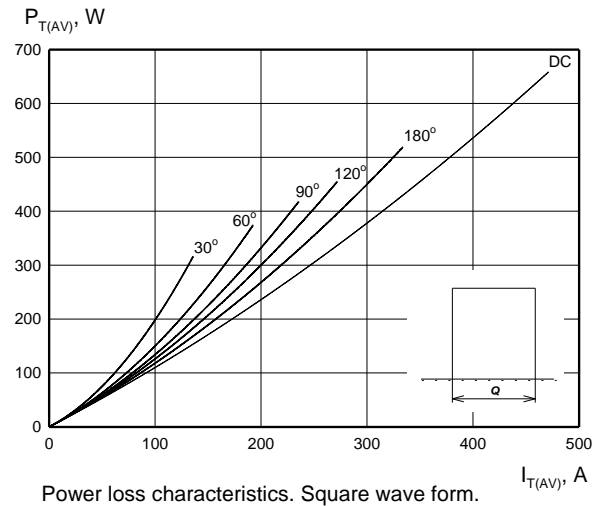
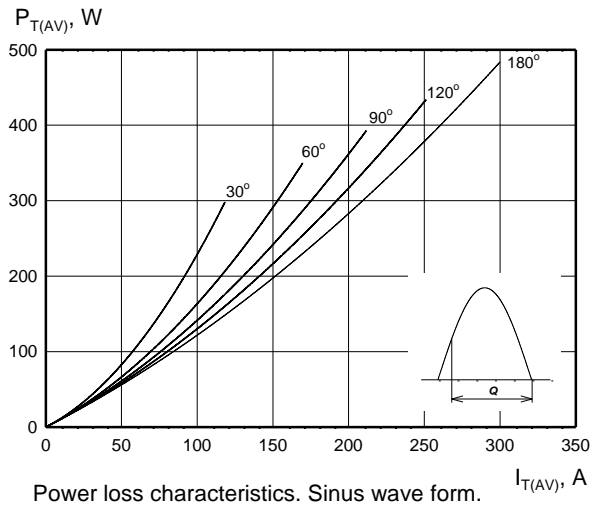

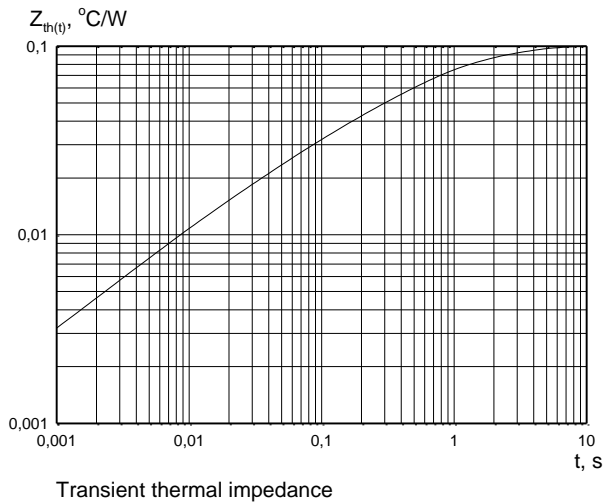
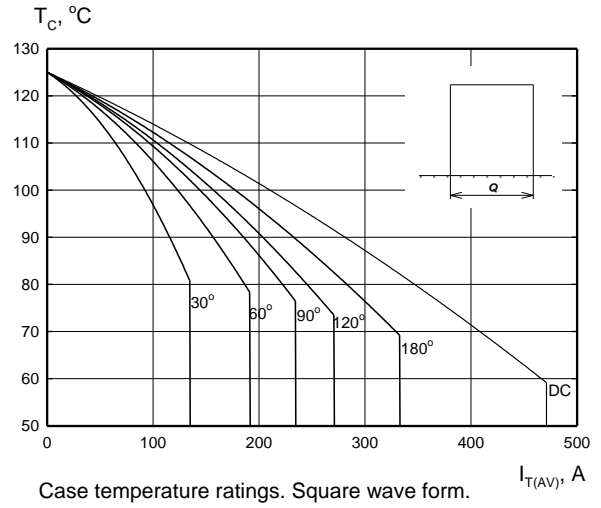
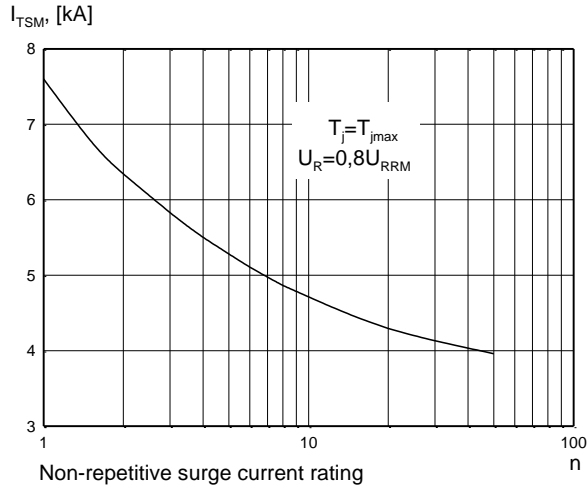

Gate characteristics

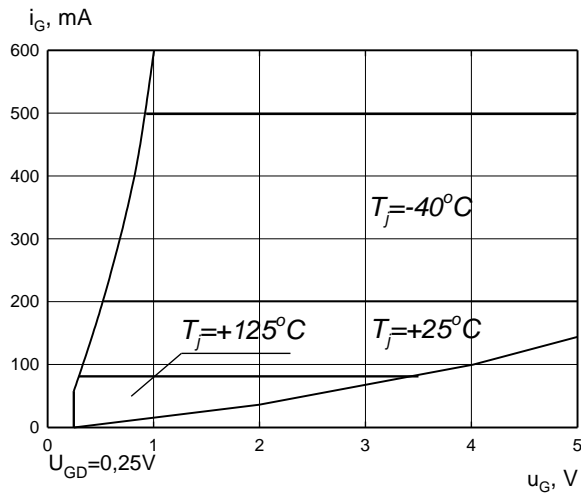

Gate characteristic. Possible trigger area.

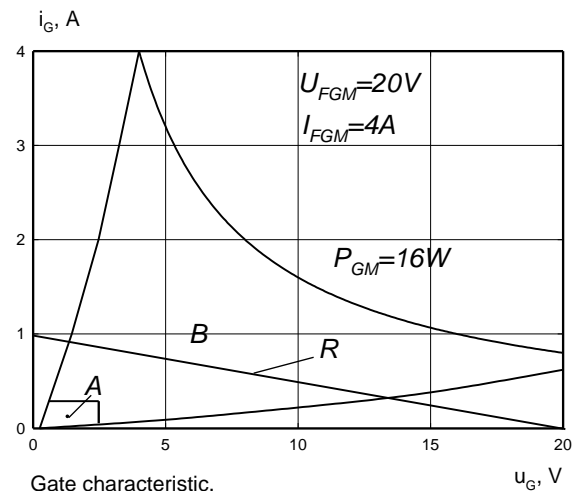

Gate characteristic.

- A - possible trigger area
- B - permitted gate pulse forcing area
- R - recommended gate drive load line

HEATSINKS

KUBARA LAMINA SA has its own proprietary range of extruded aluminium heatsinks designed to optimise the performance of our semiconductors with natural and forced air flow. High efficiency water cooled copper heatsinks are also available.

POWER ASSEMBLY CAPABILITY

KUBARA LAMINA SA provides a support for those customers requiring more than a basic semiconductor and offers precisely assembled Power Blocks according to factory or customer standards.