

Diode type D95 are of modern design with pressure contacts, high alumina ceramic insulator and cold-welding encapsulation. Designed for use in power rectifying circuits and equipment under normal operating conditions.

KEY PARAMETERS

U_{RRM}	up to 3200 V
$I_{F(AV)}$	1800 A
I_{FSM}	25000 A

FEATURES

- all diffused design
- high current capabilities
- high surge current capabilities
- high rated voltages
- low thermal impedance
- tested according to IEC standards
- compact size and small weight

APPLICATION

- High Voltage Power Supplies
- Motor Control
- Battery Chargers
- Free Wheeling Diode
- Resistance Welding

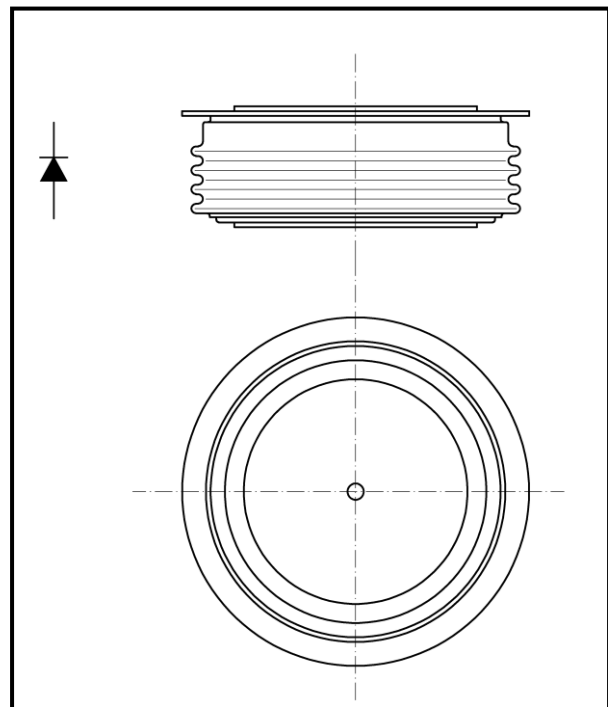

Outline type code: JEDEC DO-200AC
See Package Details for further information

Designed for use in high power industrial and commercial electronic circuits and equipment where high currents are encountered and high reliability is essential. Low forward voltages let minimize energy loss.

ORDERING INFORMATION

When ordering please refer to device code builder presented below.
Please use the complete part number when ordering, quote or in any future correspondence relating to your order.

D95-1800-

voltage class (hundreds of volts)

ELECTRICAL PARAMETERS

Voltage ratings

Voltage class	U_{RRM}	U_{RSM}	I_{RRM}
	V	V	mA
04	400	500	100
06	600	700	
08	800	900	
10	1000	1100	
12	1200	1300	
14	1400	1500	
16	1600	1700	
18	1800	1900	
20	2000	2100	
22	2200	2300	
24	2400	2500	
26	2600	2700	
28	2800	2900	
30	3000	3100	
32	3200	3300	

Electrical properties

Parameter	Unit	Test conditions	Value
Average forward current @ case temperature	$I_{F(AV)}$	A	1800
	T_c	°C	$U_{RRM} \leq 2000$ V 130 $U_{RRM} > 2000$ V 115
RMS forward current	$I_{F(RMS)}$	A	2820
Surge current	I_{FSM}	A	$T_j = 175^\circ\text{C}$, $U_R = 0,8U_{RRM}$, $t_p = 10\text{ms}$
I^2t – value	I^2t	kA^2s	3125
Forward voltage drop max.	U_{FM}	V	$T_j = 25^\circ\text{C}$, $I_{FM} = 1500\text{A}$
Threshold voltage	$U_{F(T0)}$	V	0,81
Slope resistance	r_F	$\text{m}\Omega$	0,162
Reverse recovery charge	Q_r	μC	$T_j = 25^\circ\text{C}$, $I_{FM} = 1500\text{A}$, $di_R/dt = 25\text{A}/\mu\text{s}$

Thermal properties

Parameter		Unit	Test conditions	Value
Thermal resistance, junction to case	R_{thJC}	°C/W	two sided, DC	0,02
Thermal resistance, case to heatsink	R_{thCS}	°C/W	two sided	0,010
Operating junction temperature	$T_{jmin}...T_{jmax}$	°C		$U_{RRM} \leq 2000\text{ V}$ -40...+190 $U_{RRM} > 2000\text{ V}$ -40...+175
Storage temperature	T_{stg}	°C		-40...+190

Mechanical properties

Parameter		Unit	Value
Clamping force	F_M	kN	22,5 ... 25,0
Weight	m	g	480

Package details

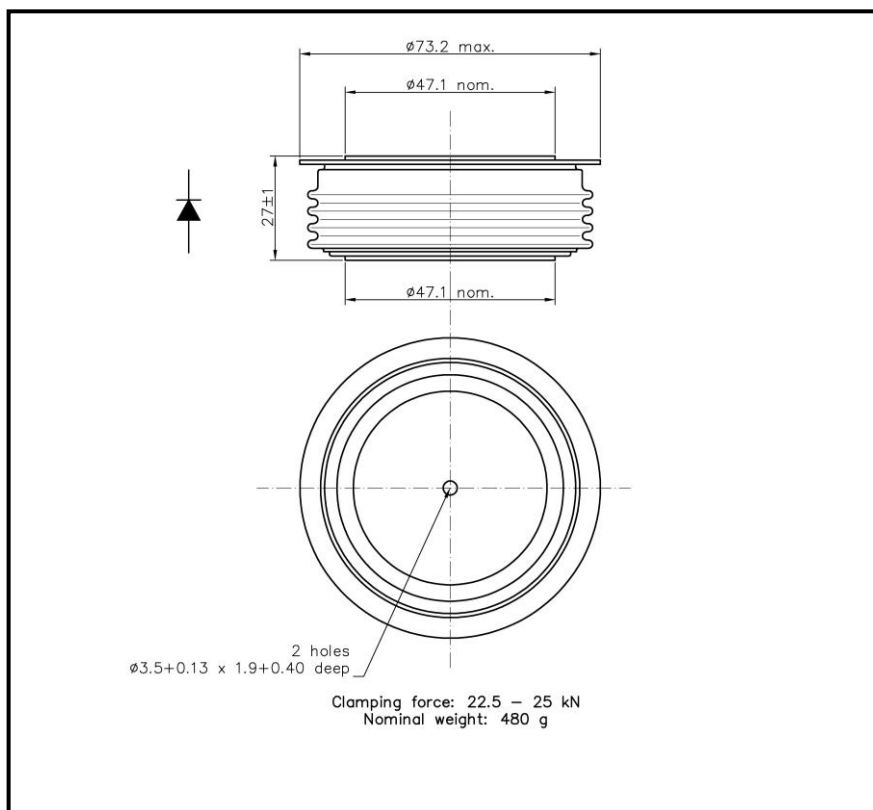

For further package information, please contact Sales & Marketing Department. All dimensions in mm, unless stated otherwise. Do not scale.

CHARACTERISTICS

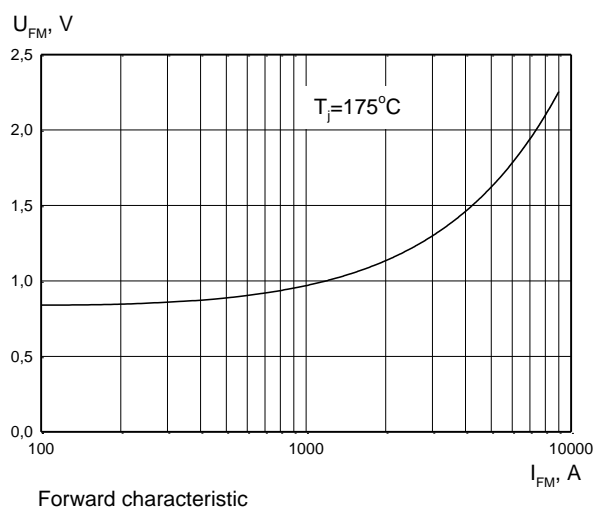
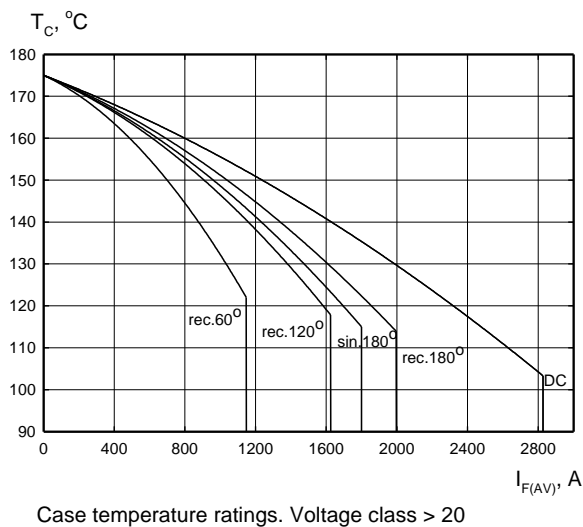
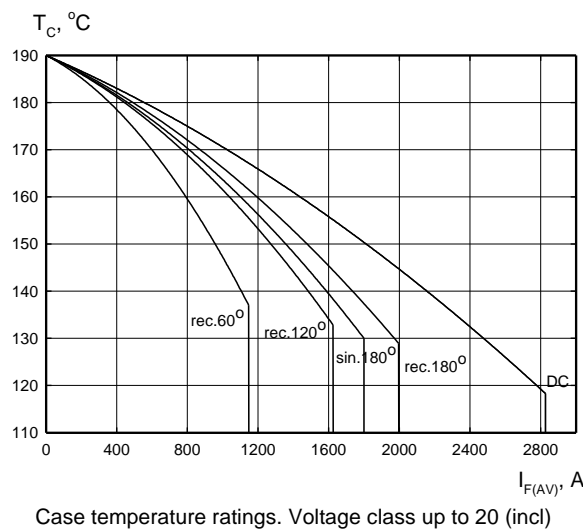
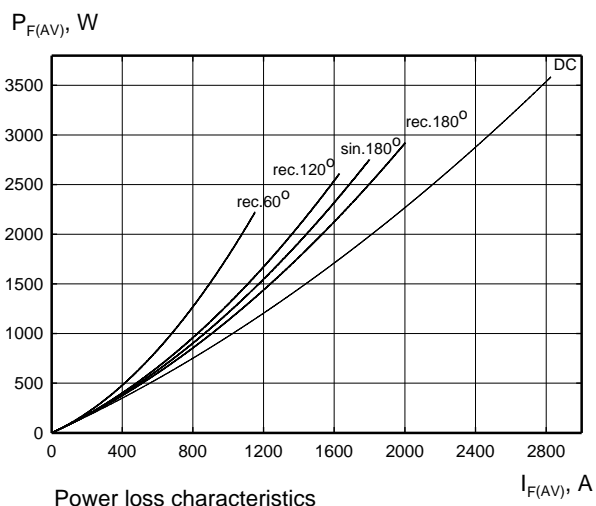

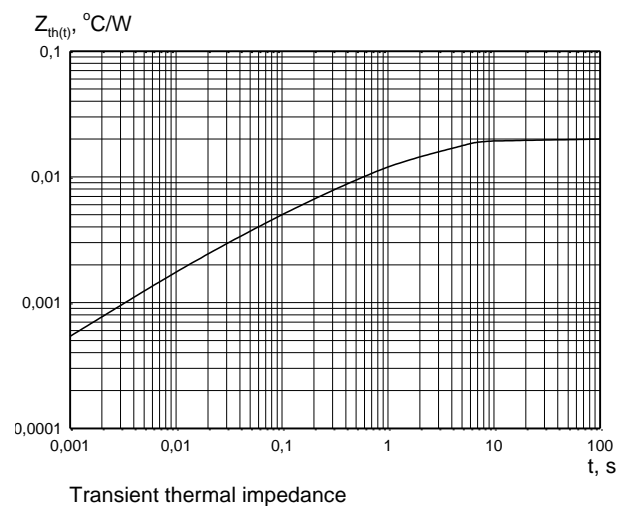
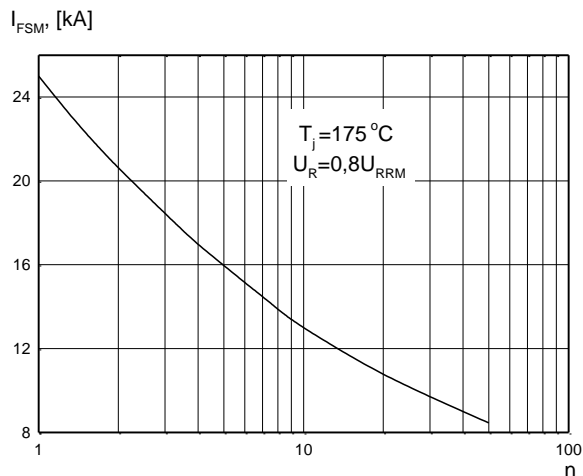

HEATSINKS

KUBARA LAMINA SA has its own proprietary range of extruded aluminium heatsinks designed to optimise the performance of our semiconductors with natural and forced air flow. High efficiency water cooled copper heatsinks are also available.

DEVICE CLAMPS

Disc devices require the correct clamping force to ensure their best operation.

KUBARA LAMINA SA offers a wide selection of clamps to suit all of our manufactured devices.

POWER ASSEMBLY CAPABILITY

KUBARA LAMINA SA provides a support for those customers requiring more than a basic semiconductor and offers precisely assembled Power Blocks according to factory or customer standards.