



# Soft Recovery Diode ADDM1494ND250



## Key Parameters

$V_{RRM}$	=	2500 V
$V_{RSM}$	=	2600 V
$V_R$	=	1500 V
$I_{F(av)M}$	=	1494 A

	OTHER RATINGS	MAXIMUM LIMITS	UNITS
$I_{F(av)M}$	Maximum average forward current, $T_{sink}=55^{\circ}C$	1494	A
$I_{F(av)M}$	Maximum average forward current. $T_{sink}=100^{\circ}C$	705	A
$I_{F(av)M}$	Maximum average forward. $T_{sink}=100^{\circ}C$	402	A
$I_{F(RMS)}$	Nominal RMS forward current, $T_{sink}=25^{\circ}C$	2982	A
$I_{F(d.c.)}$	D.C. forward current, $T_{sink}=25^{\circ}C$	2506	A
$I_{FSM}$	Peak non-repetitive surge $t_p=10ms$ , $V_{RM}=60\%V_{RRM}$	19.6	kA
$I_{FSM2}$	Peak non-repetitive surge $t_p=10ms$ , $V_{RM}\leq 10V$	21.5	kA
$I^2t$	$I^2t$ capacity for fusing $t_p=10ms$ , $V_{RM}=60\%V_{RRM}$	$1.92 \times 10^6$	$A^2s$
$I^2t$	$I^2t$ capacity for fusing $t_p=10ms$ , $V_{RM}\leq 10V$	$2.31 \times 10^6$	$A^2s$
$T_{j op}$	Operating temperature range	-40 to +125	$^{\circ}C$
$T_{stg}$	Storage temperature range	-40 to +150	$^{\circ}C$

	PARAMETER	MIN.	TYP.	MAX.	TEST CONDITIONS	UNITS
V <sub>FM</sub>	Maximum peak forward voltage	-	-	1.85	I <sub>FM</sub> =3000A	V
		-	-	2.34	I <sub>FM</sub> =4500A	V
V <sub>T0</sub>	Threshold voltage	-	-	1.150		V
r <sub>T</sub>	Slope resistance	-	-	0.265		mΩ
V <sub>FRM</sub>	Maximum forward recovery voltage	-	-	45	di/dt = 1000A/μs	V
		-	-	28	di/dt = 1000A/μs, T <sub>j</sub> = 25°C	
I <sub>RRM</sub>	Peak reverse current	-	-	85	Rated V <sub>RRM</sub>	mA
Q <sub>rr</sub>	Recovered charge	-	815	-		μC
Q <sub>ra</sub>	Recovered charge, 50% Chord	-	275	380	I <sub>FM</sub> =1000A, t <sub>p</sub> =1000μs, di/dt=60A/μs,	μC
I <sub>rm</sub>	Reverse recovery current	-	140	-	V <sub>r</sub> =50V, 50% Chord.	A
t <sub>rr</sub>	Reverse recovery time, 50% Chord	-	3.9	-		μs
R <sub>thJK</sub>	Thermal resistance, junction to heatsink	-	-	0.022	Double side cooled	K/W
		-	-	0.044	Single side cooled	
F	Mounting force	19	-	26		kN
W <sub>t</sub>	Weight	-	510	-		g

DIMENSIONES

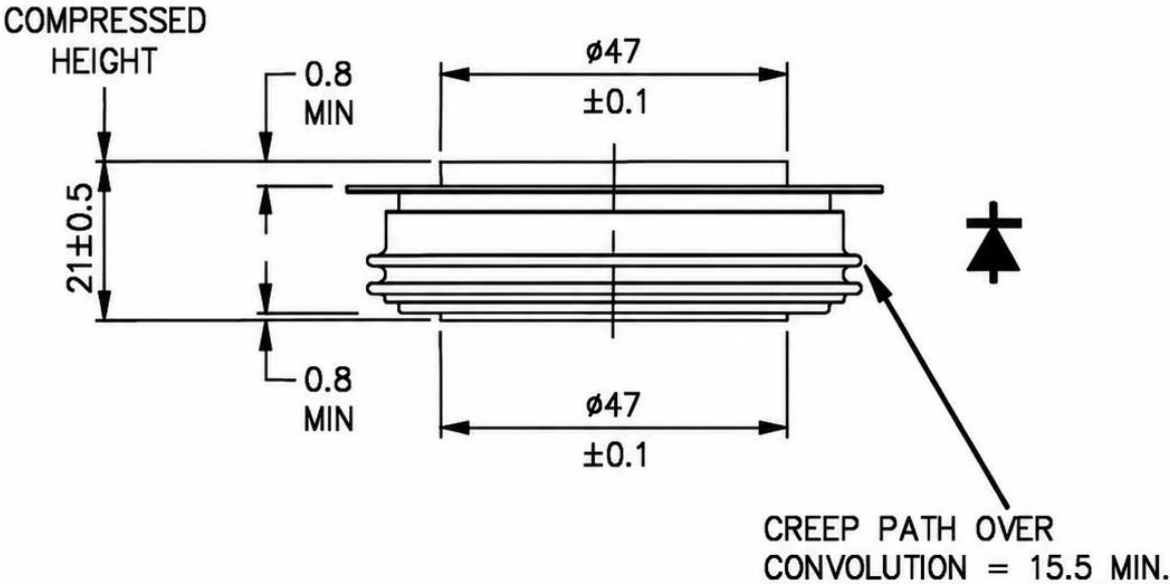
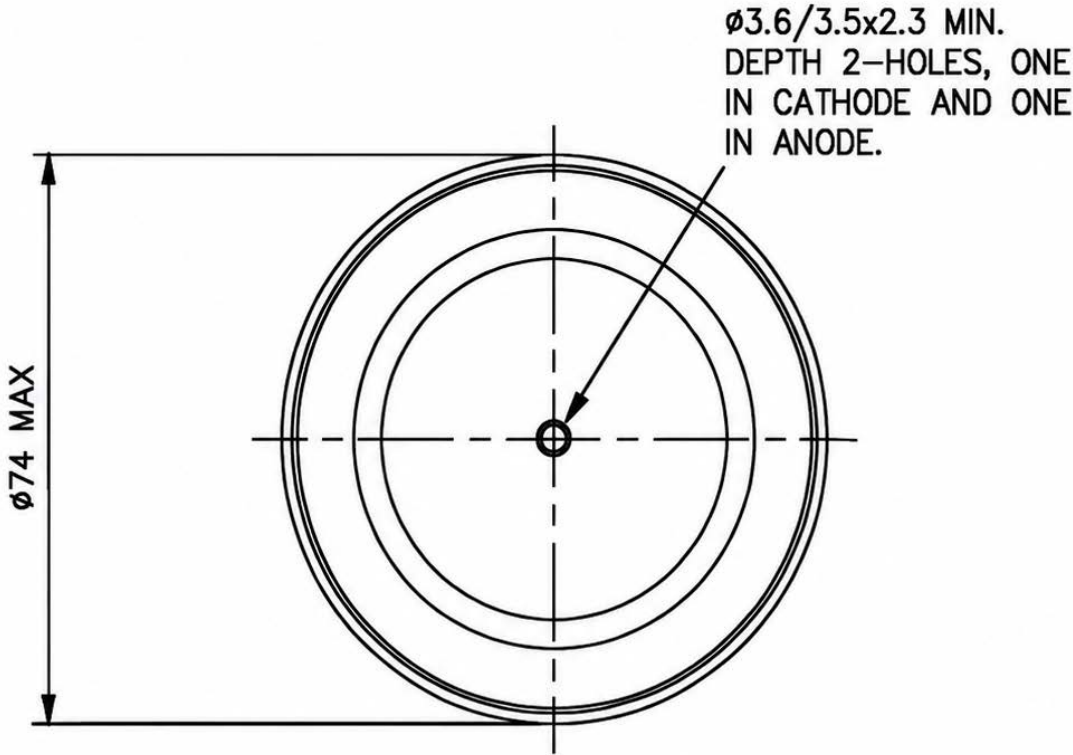

All dimensions in millimeters

Figure 1 – Forward characteristics of Limit device

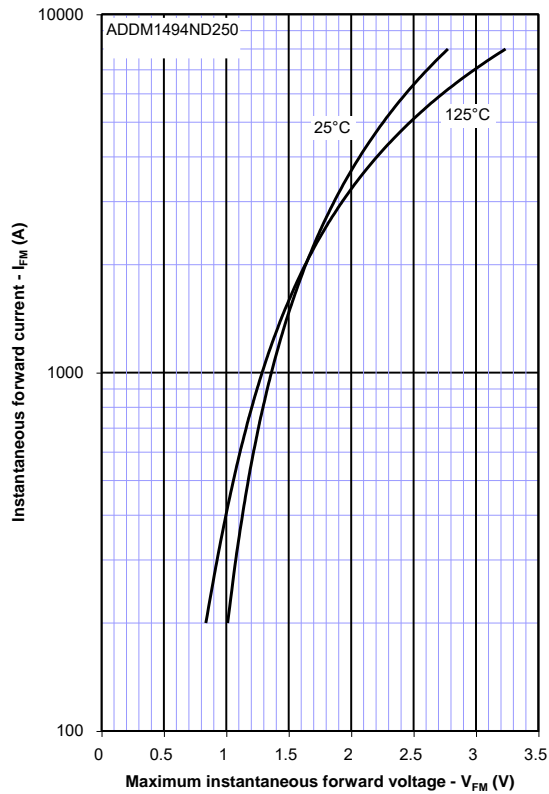

Figure 2 – Maximum forward recovery voltage

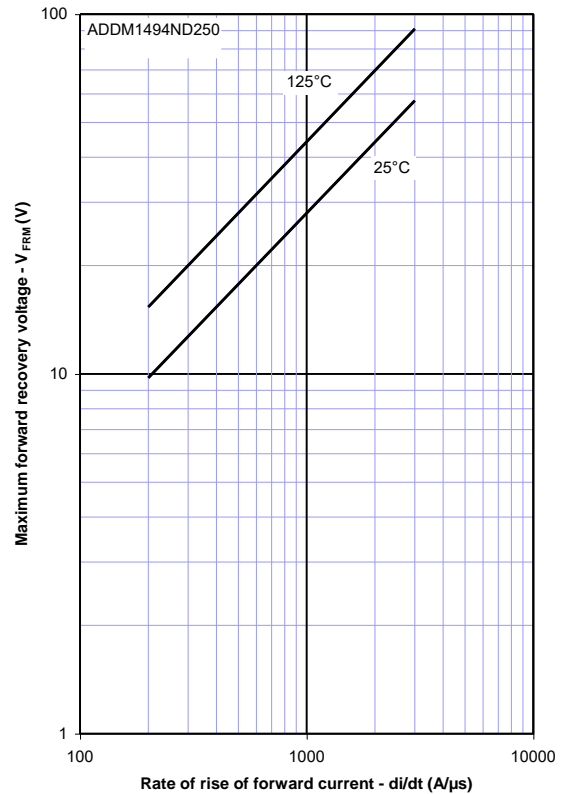

Figure 3 - Recovered charge,  $Q_{rr}$

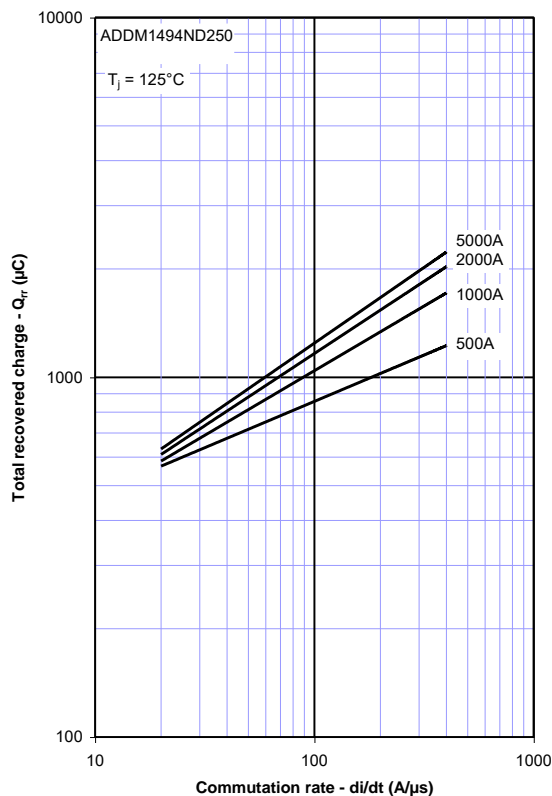

Figure 4 - Recovered charge,  $Q_{ra}$  (50% chord)

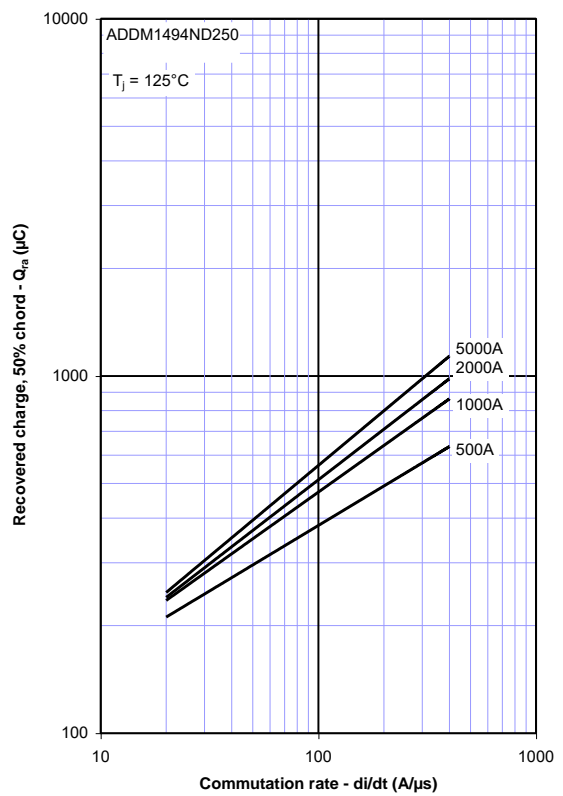

Figure 5 - Maximum reverse current,  $I_{rm}$

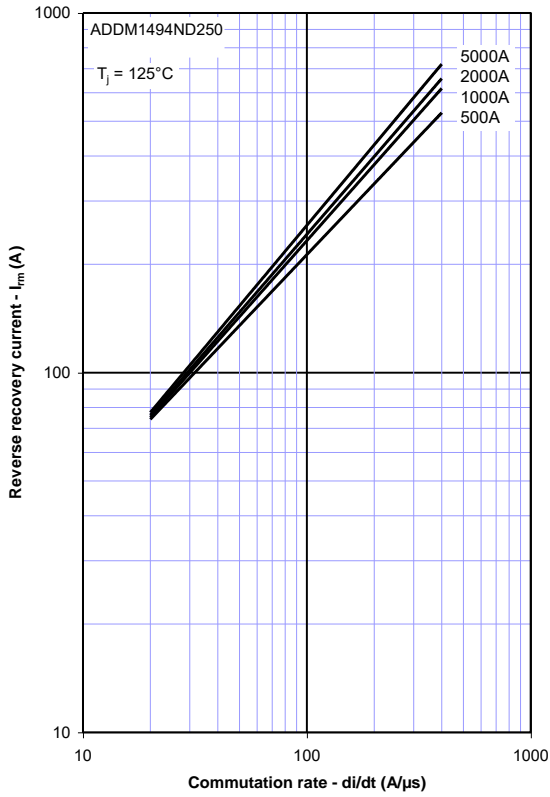

Figure 6 - Maximum recovery time,  $t_{rr}$  (50% chord)

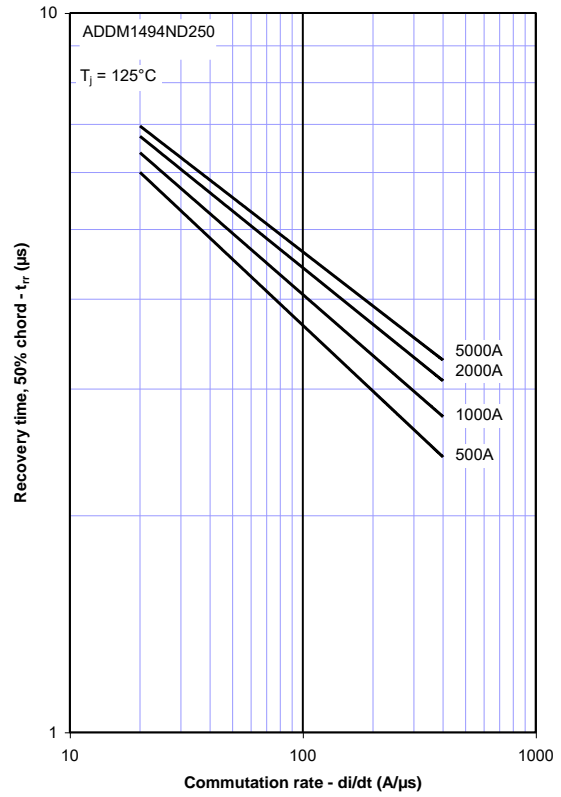

Figure 7 - Reverse recovery energy per pulse

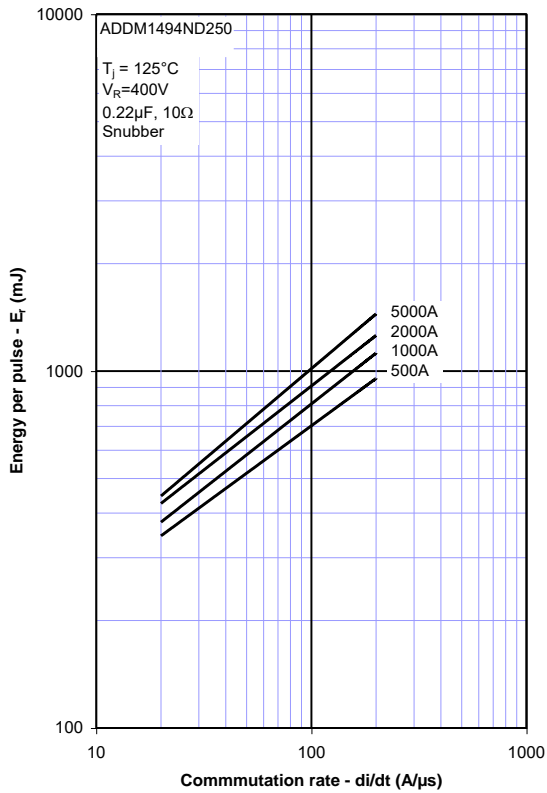

Figure 8 - Sine wave energy per pulse

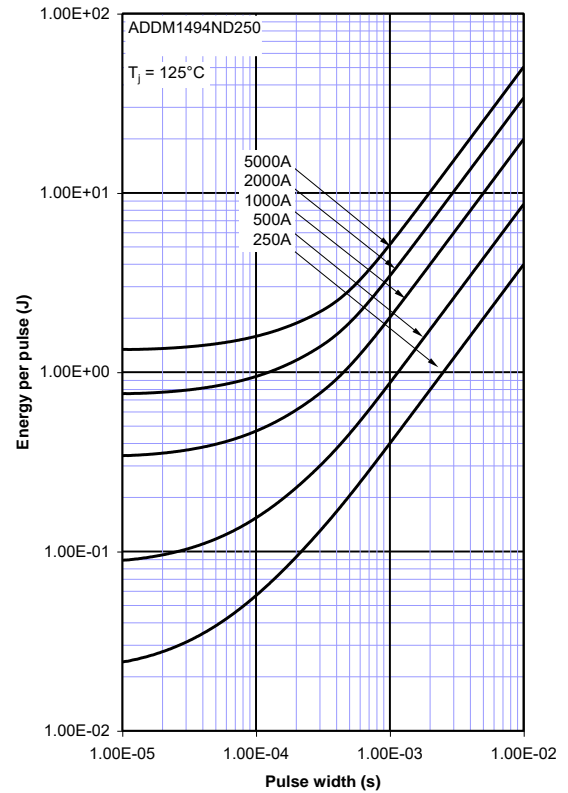

Figure 9 - Sine wave frequency vs. pulse width

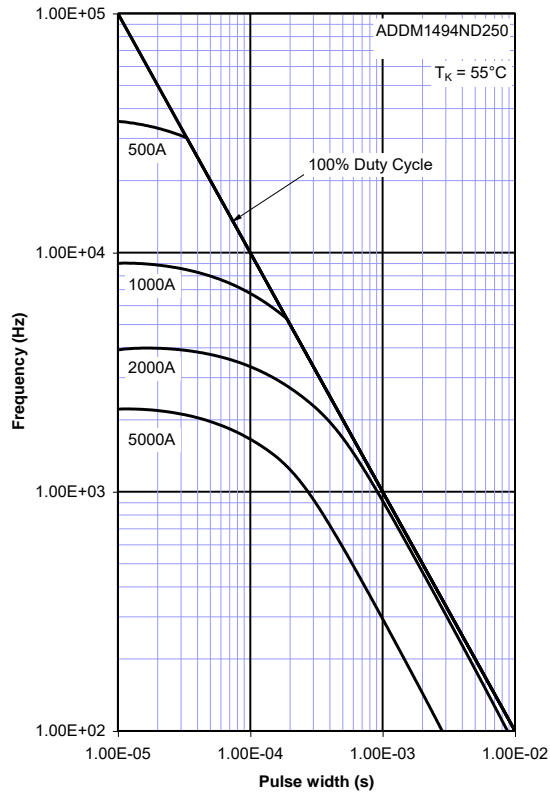

Figure 10 - Sine wave frequency vs. pulse width

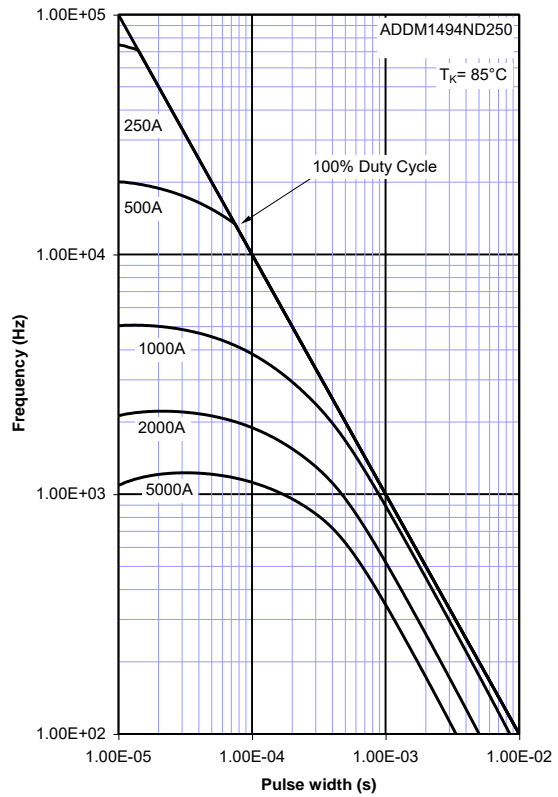

Figure 11 - Square wave energy per pulse

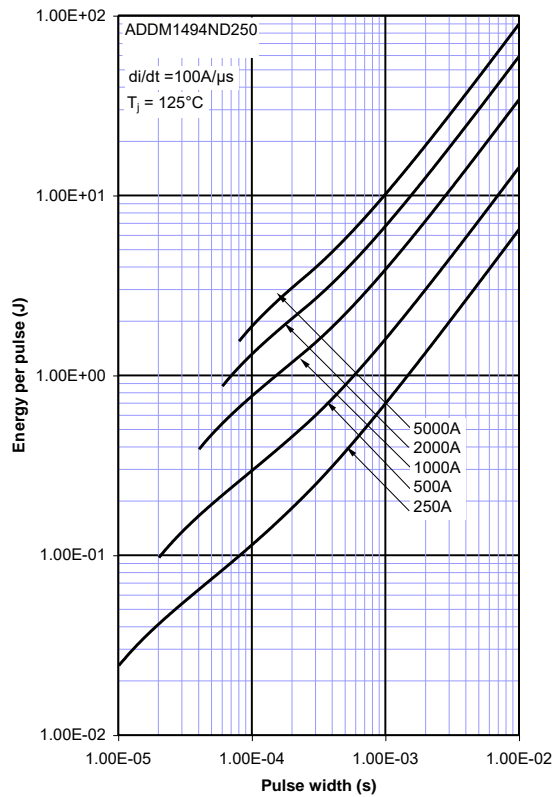

Figure 12 - Square wave energy per pulse

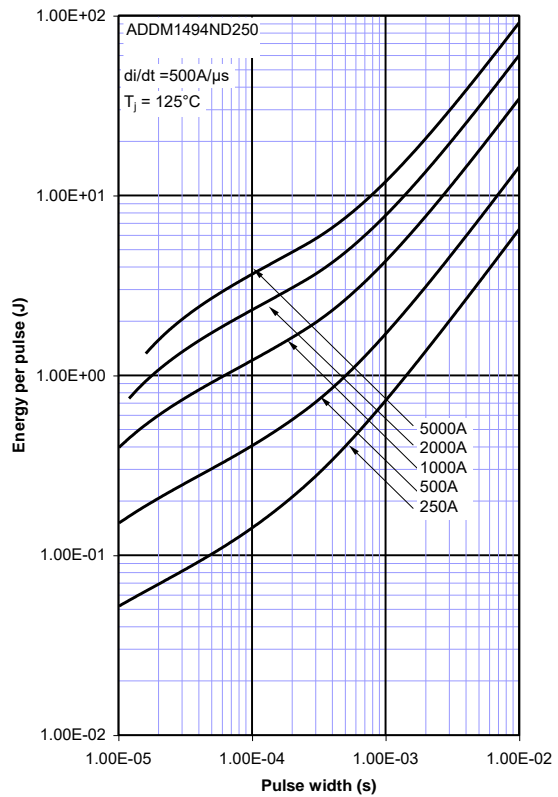

Figure 13 - Square wave frequency vs. pulse width

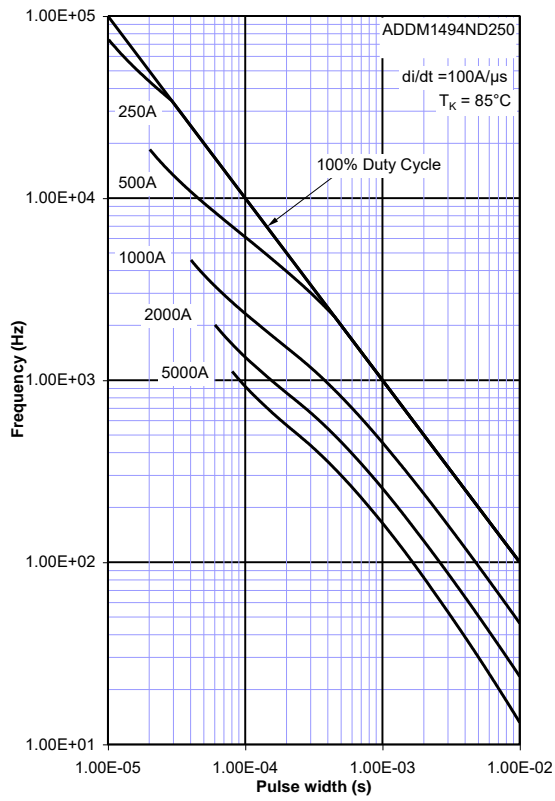

Figure 14 - Square wave frequency vs. pulse width

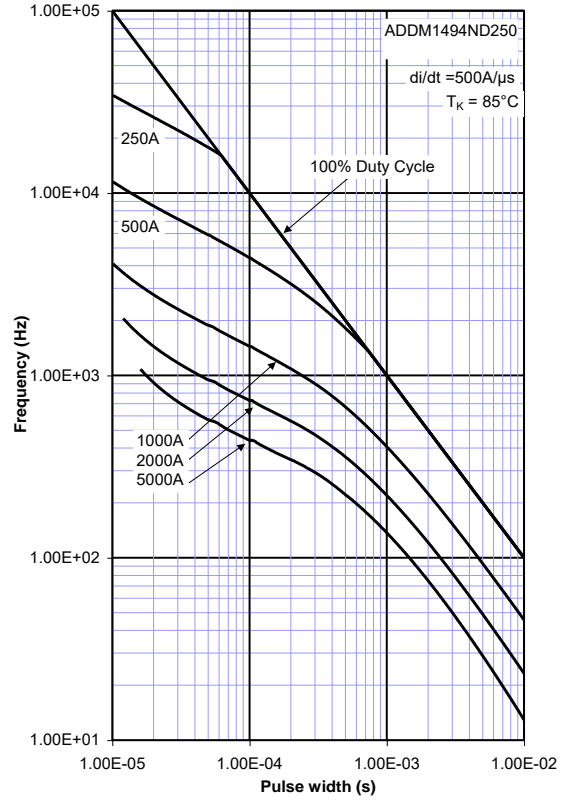

Figure 15 - Square wave frequency vs. pulse width

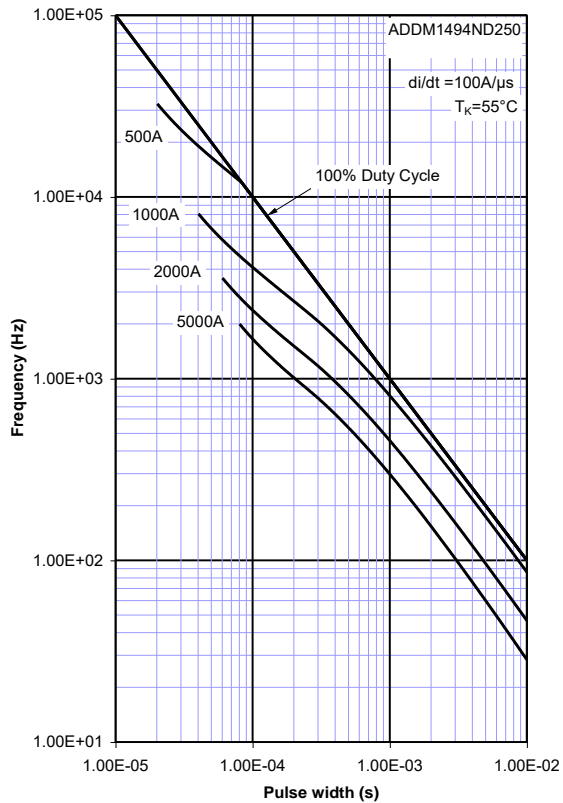

Figure 16 - Square wave frequency vs. pulse width

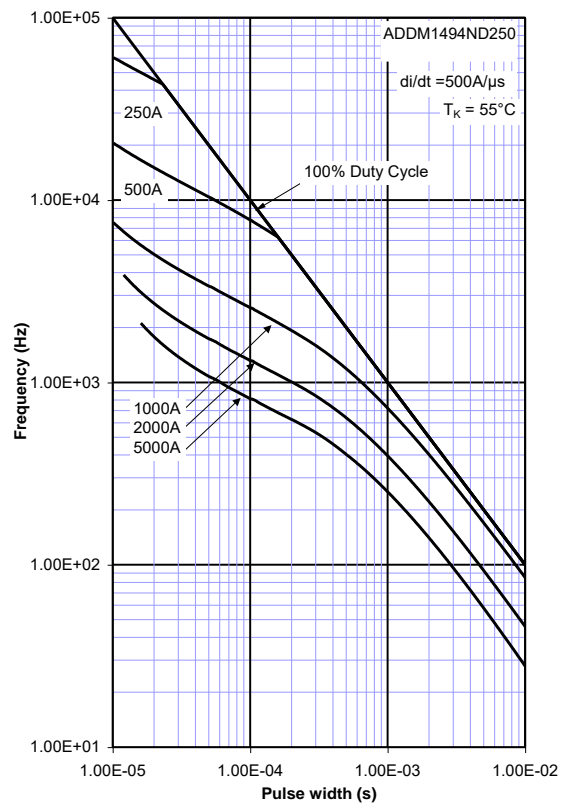

Figure 17 – Maximum surge and I<sup>2</sup>t ratings

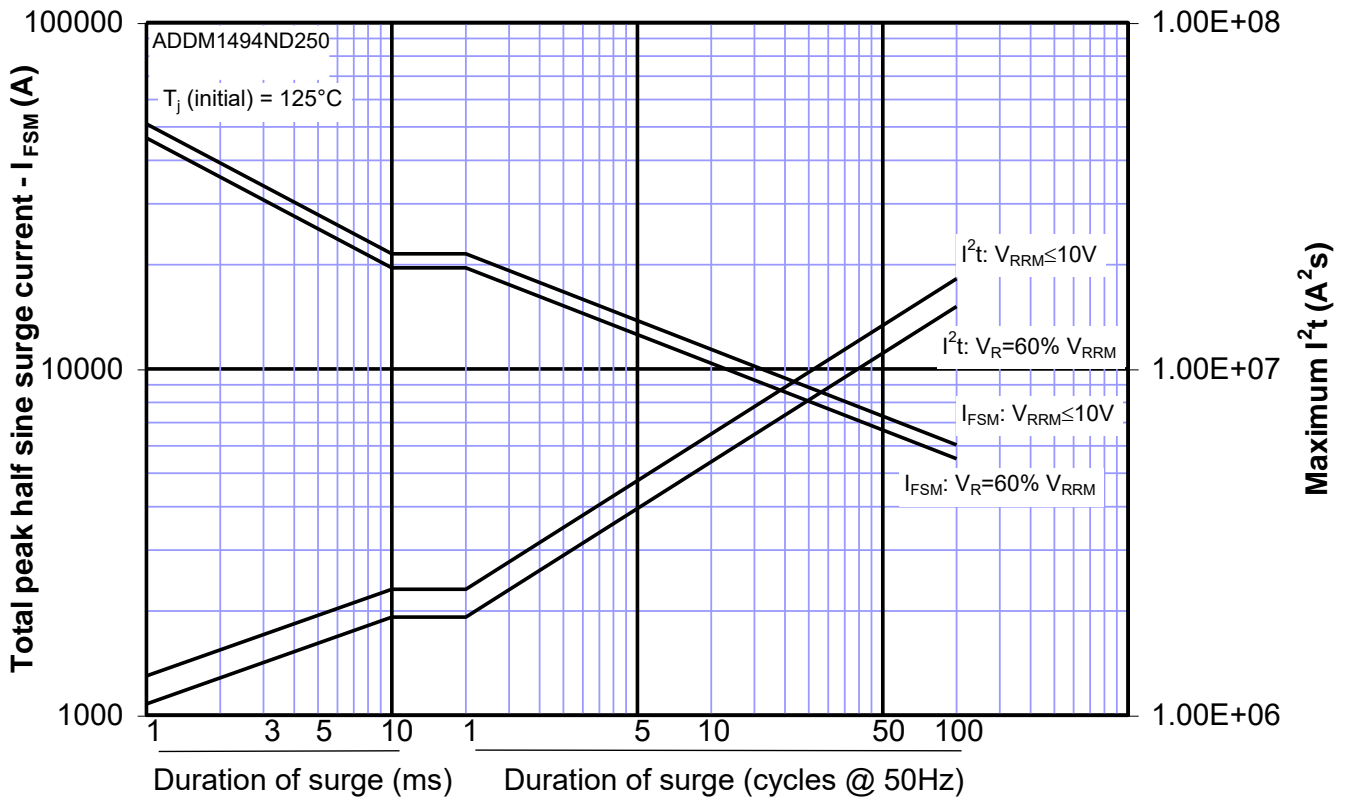

Figure 18 – Transient thermal impedance

