

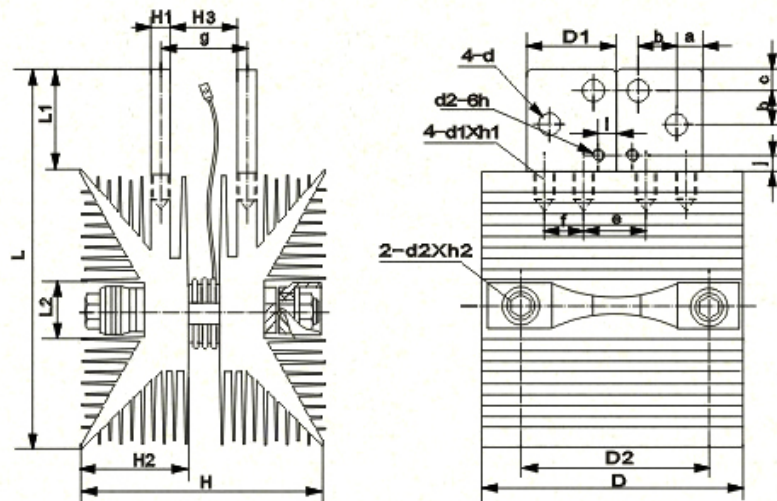

Air-cooling Heatsinks SF18 for Power Semiconductor Devices

Type	Outline Dimensions, mm			Conductor Plate Dimensions, mm		
	L	D	H	L1	D1	H1
SF18	390	240	225	90	70	13

Type	Install Dimensions, mm															
	L2	D2	H2	H3	d	d1xh1	a	b	c	e	f	g	l	j	h	d3
SF18	45	150	100	72	4 holes Ø13	4 screw holes M8- 6H-20	22.5	25	20	80	50	85	8	20	25	M3



Heatsink SF18
forced air-cooling for disc semiconductor devices